

# Future Colliders for the Energy Frontier

Carmen García



**Taller de Altas Energías 2014, Sep 14 - Sep 27.**  
**(Centro de Ciencias de Benasque Pedro Pascual)**

# OVERLOOK

- Particle accelerators immensely powerful tools for understanding the standard model and to search for new physics.
- Long history of colliding beam experiments with spectacular results
- Short report of our actual energy frontier (LHC), as input to to guide the future  
(many think already seen in Ignacio Redondo talk).
- Future possibilities are examined will examine.

- Sorry for any technical mistake (I am just a accelerator user).
- This is also a very personal view.

# Evolution of Colliders - past and present

N. Walker

Long history of high energy acceleration

- Proton-(anti-)Proton
- Electron-Positron
- Electron-hadron

Exponential increase in beam energy

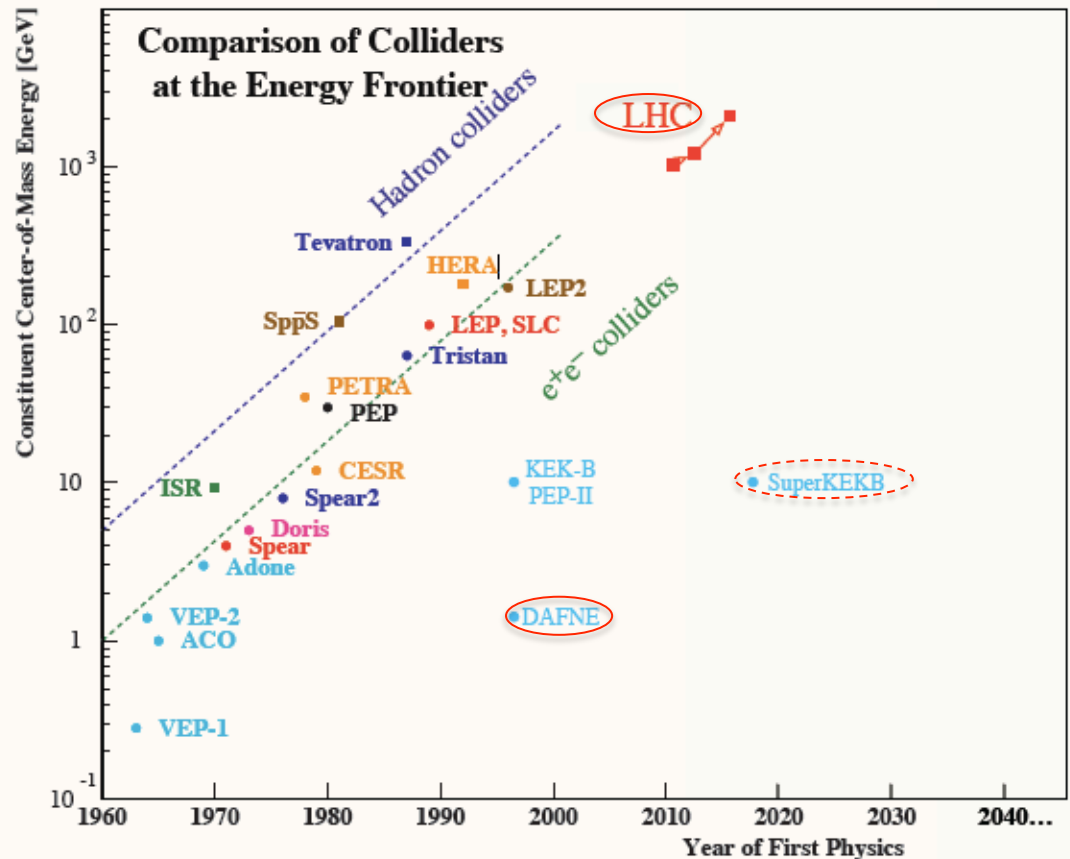



# Tools for discoveries...

209109

Event: 76170653

2012-08-24 09:31:00 CEST

 **ATLAS**  
EXPERIMENT  
<http://atlas.ch>

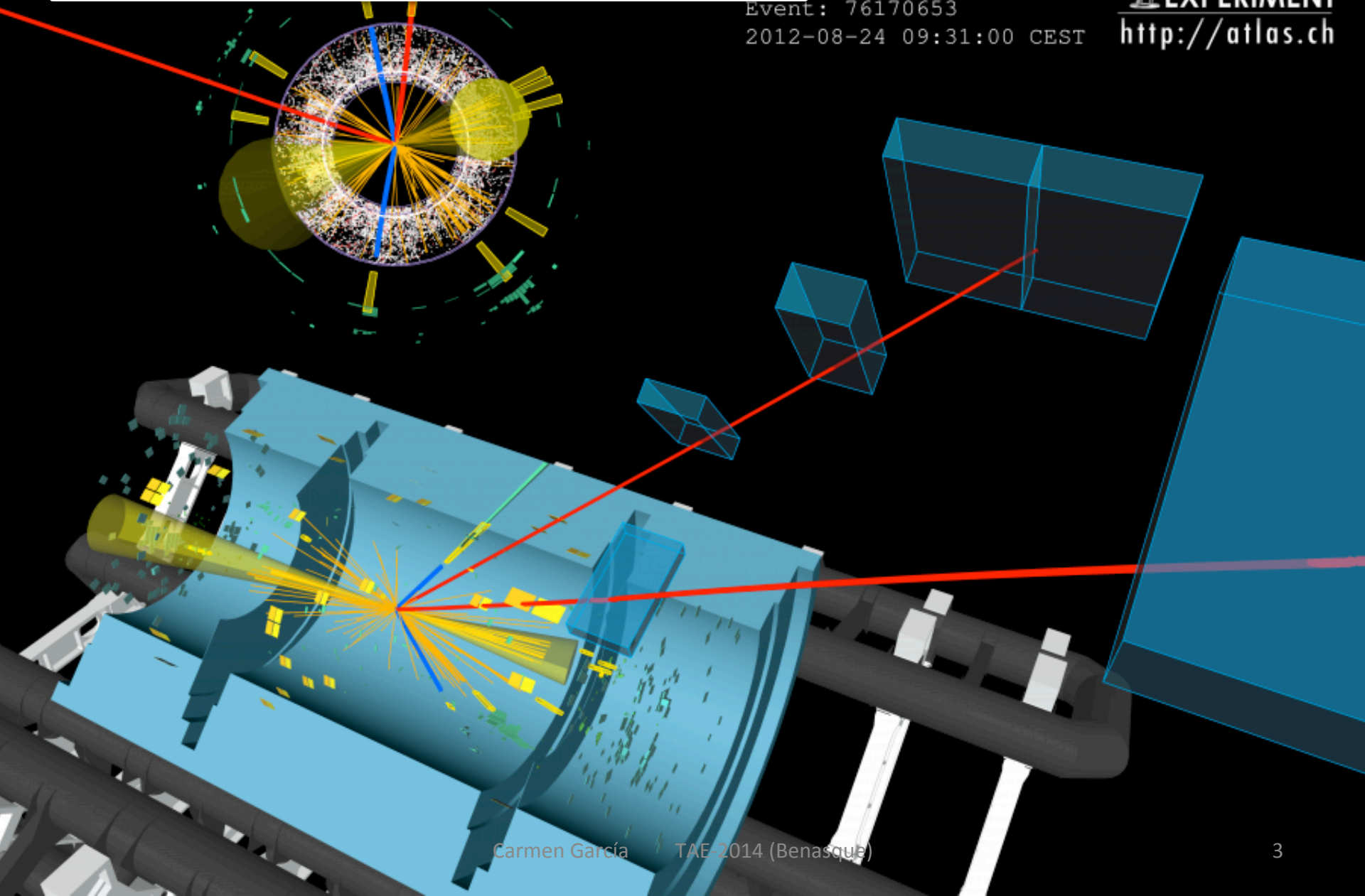



# High energy acceleration has given some of the most powerful insights into constituents of matter and their interactions

Strong nuclear force:  
gluons discovery

Electroweak vector  
bosons: dicoverly of  
(W,Z)

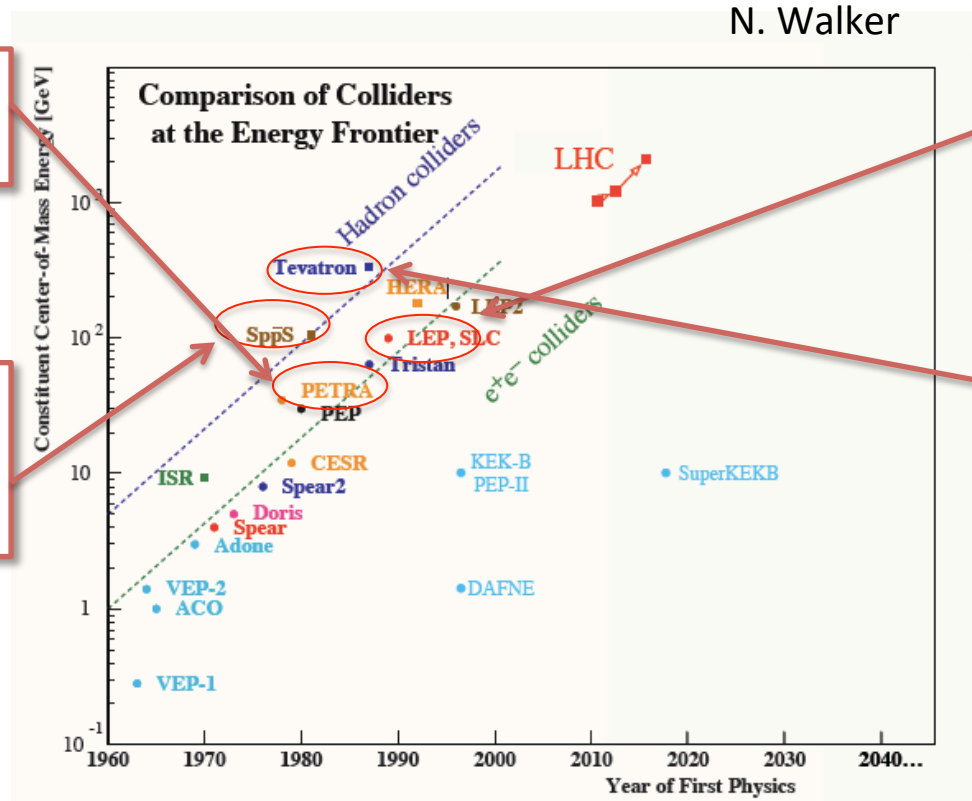

Electroweak vector  
bosons: precision  
measurements

Top discovery

# The Current Energy Frontier: LHC



# Higg Discovery

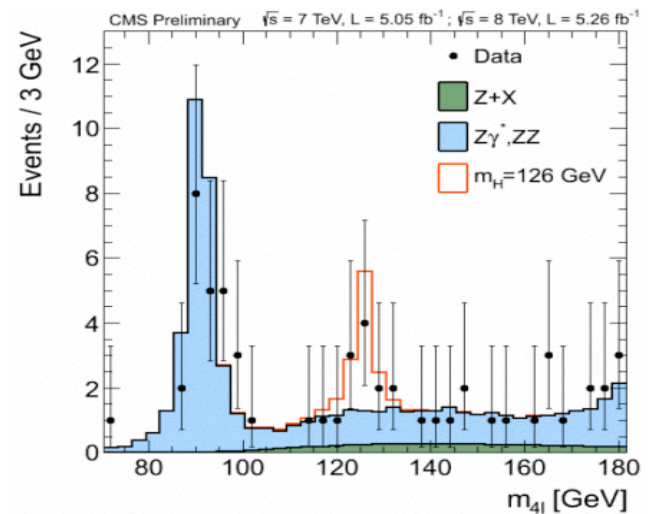
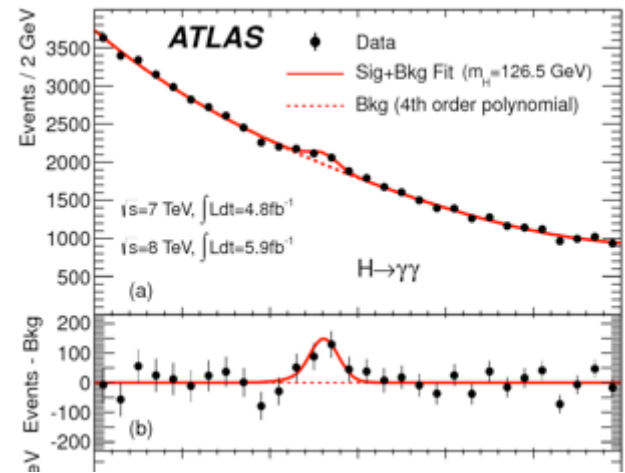



# Priorities of collider physics after Higgs discovery

- The recently discovered of a Higgs boson drives to a number of fundamental open points that are **top priority for the physics programme for LHC and FUTURE COLLIDERS** :
  - Precision measurement of the **mass** and **natural width** determination.
  - Determination of the **quantum numbers** spin and parity,  $J^P$ , and CP violation.
  - Measurement of **couplings** to elementary fermions and bosons
  - Measurement of the **Higgs boson pair** production.
  - **Comparison** of these physics properties with those predicted by Standard Model.
  - **Search for possible partners** (neutral and/or charged) of this boson
  - Is this particle a **fundamental object, or it is composite?**.
- However, the investigations of the electroweak symmetry breaking cannot be limited to the study of the Higgs sector only. Several points still to be addressed, among these:
  - The dependence with energy of the **Vector Boson Scattering** cross section  $d\sigma/dm_{VV}$  (WW, WZ and ZZ)
  - The hierarchy problem, motivated **new theories beyond SM**, such as Supersymmetry, Extra-Dimensions, Technicolor models. Searching for physics BSM include:
    - Direct search for new particle (SUSY partners , resonances, etc.).
    - Indirect effect: FCNC in top decays...

# Priorities of collider physics after Higgs discovery

- The recently discovered of a Higgs boson drives to a number of fundamental open points that are **top priority for the physics programme for LHC and FUTURE COLLIDERS** :
  - Precision measurement of the **mass** and **natural width** determination.
  - Determination of the **quantum numbers** spin and parity,  $J^P$ , and CP violation.
  - Measurement of **couplings** to elementary fermions and bosons
  - Measurement of the **Higgs boson pair** production.
  - **Comparison** of these physics properties with those predicted by the SM model.
  - **Search for possible partners** (neutral and/or charged) of the Higgs boson.
  - Is this particle a **fundamental object, or it is composite**?
- However, the investigations of the electroweak symmetry breaking cannot be limited to the study of the Higgs sector only. Several issues still to be addressed, among these:
  - The dependence with energy of the **vector boson scattering** cross section  $d\sigma/dm_{VV}$  (WW, WZ and ZZ)
  - The hierarchy problem, motivating **theories beyond SM**, such as Supersymmetry, Extra-Dimensions, Technicolor models. Searching for possible BSM include:
    - Direct search for new particle (SUSY partners, resonances, etc.).
    - Indirect effect: FCNC in top decays...

# LHC: Scheduling and Baseline Luminosity

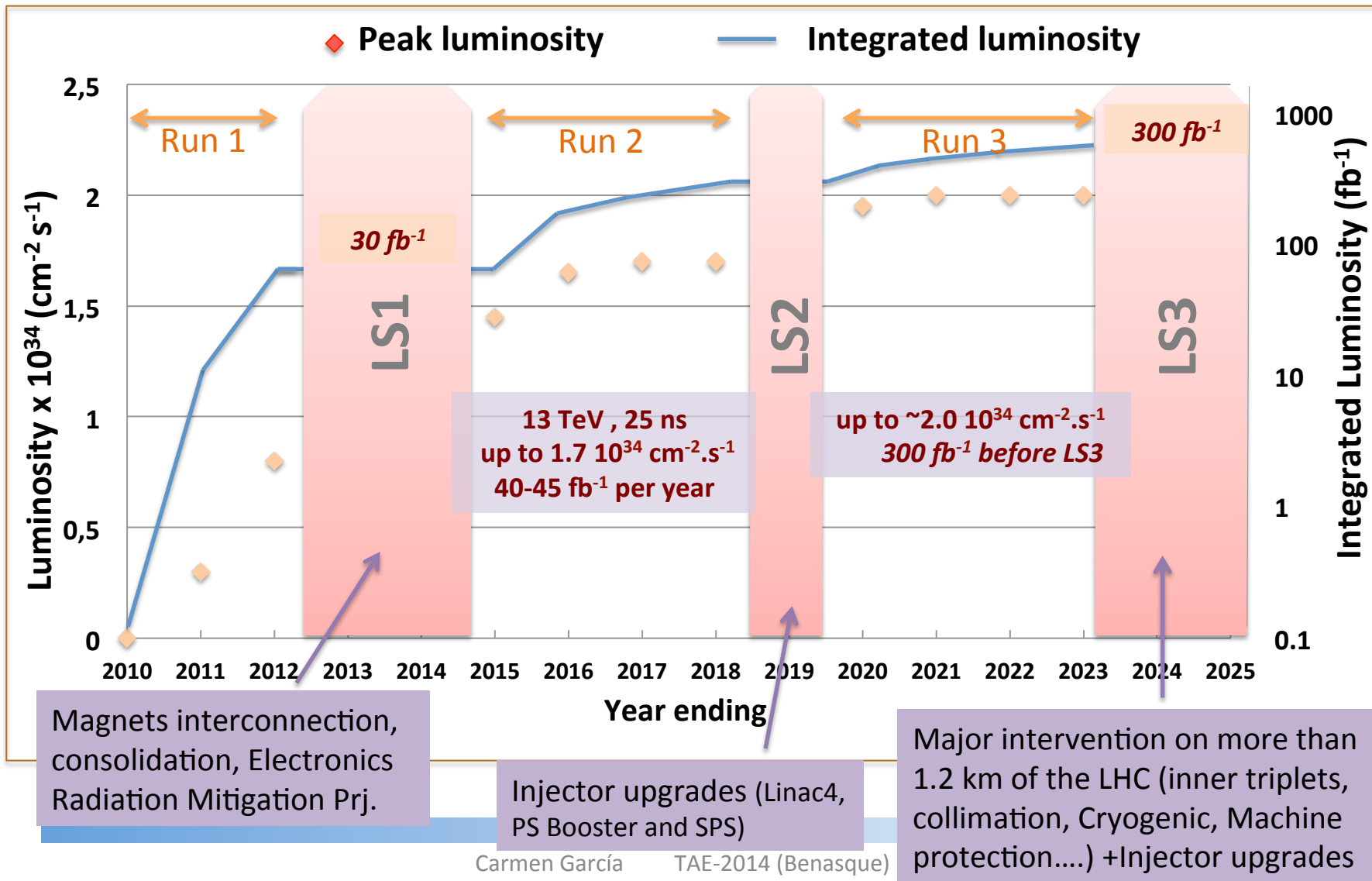



# The plan of HL-LHC (Baseline)

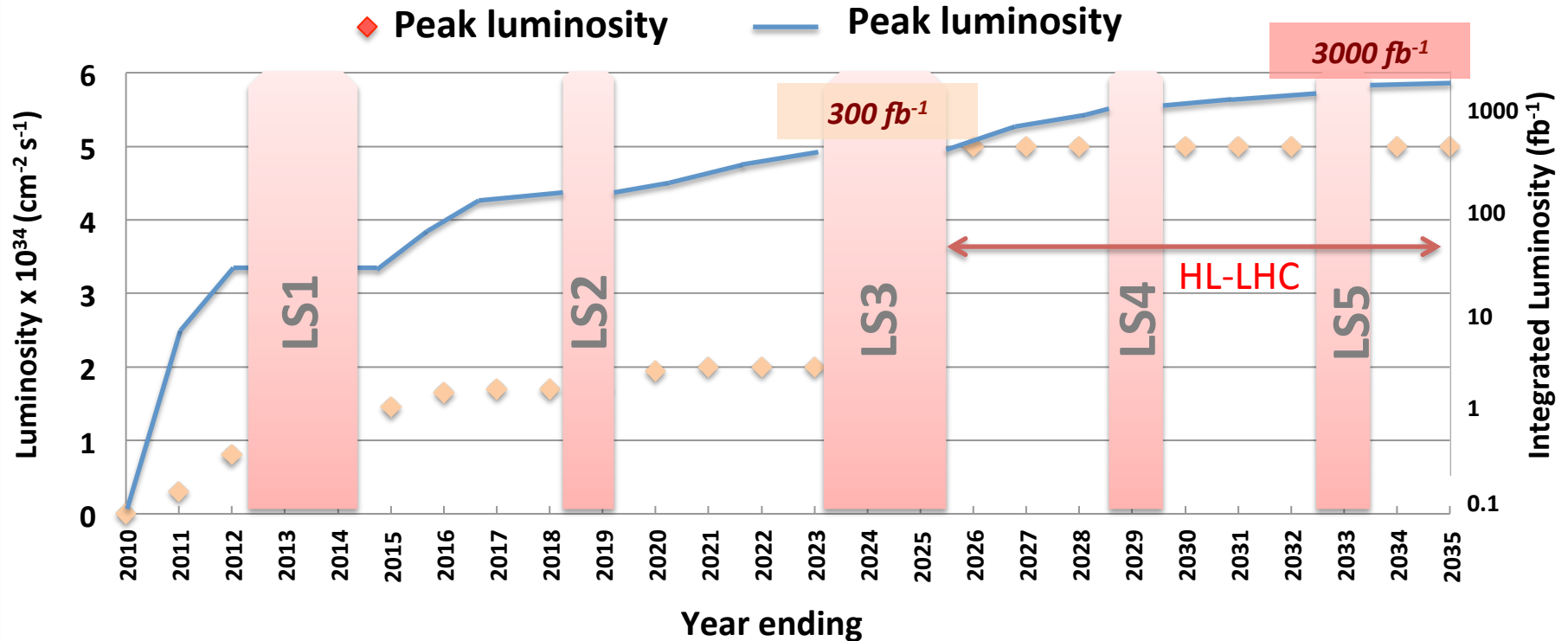

At  $5 \times 10^{34} \text{ cm}^{-2} \text{ s}^{-1}$ : 140 events/crossing in average, at 25 ns

Total integrated luminosity of  $3000 \text{ fb}^{-1}$  for p-p by 2035-2036, with LSs taken into account and 1 month for ion physics per year.

**Update of the European Strategy** for Particle Physics adopted 30 May 2013 in a special session of CERN Council at Brussels.

**Statement c:**

c) The discovery of the Higgs boson is the start of a major programme of work to measure this particle's properties with the highest possible precision for testing the validity of the Standard Model and to search for further new physics at the energy frontier. The LHC is in a unique position to pursue this programme. ***Europe's top priority should be the exploitation of the full potential of the LHC, including the high-luminosity upgrade of the machine and detectors with a view to collecting ten times more data than in the initial design, by around 2030.*** This upgrade programme will also provide further exciting opportunities for the study of flavour physics and the quark-gluon plasma.

**Very Important step in the approval of the HL-LHC project**, but it still needs formal approval.

The present CERN Mid Term Plan approved by CERN Council covers up to 2018 (LS2), but not beyond.

- Need to further elaborate physics capabilities.
- Need experiments and machine to demonstrate feasibility, and consolidate timeline and cost estimates.
- Convince funding agencies.

# Strategic Plan for U.S. Particle Physics (P5)

## Table 1 Summary of Scenarios

HL-LHC is a Global effort

Project/Activity	Scenarios			Science Drivers					Technique (Frontier)
	Few money Scenario A	A bit of money Scenario B	A lot of money Scenario C	Higgs	Neutrinos	Dark Matter	Cosm. Accel.	The Unknown	
<b>Large Projects</b>									
Muon program: Mu2e, Muon g-2	Y, <small>Mu2e small reprofile needed</small>	Y	Y					✓	I
HL-LHC	Y	Y	Y	✓		✓		✓	E
LBNF + PIP-II	Y, <small>LBNF components delayed relative to Scenario B.</small>	Y	Y, enhanced		✓			✓	I,C
ILC	R&D only	R&D, <small>possibly small hardware contributions. See text.</small>	Y	✓		✓		✓	E
NuSTORM	N	N	N		✓				I
RADAR	N	N	N		✓				I



# The road to define Physics Capabilities

## MAIN MILESTONES

- Update of the **European Strategy** for Particle Physics (signed on 30th of May 2013)
- **Snowmass** (summer 2013)
- **ECFA HL-LHC** Upgrade workshop
  - The first large meeting of the community
  - The start of a series of regular workshops (**next: October 2014**)



# Evolution of Colliders - the future

N. Walker

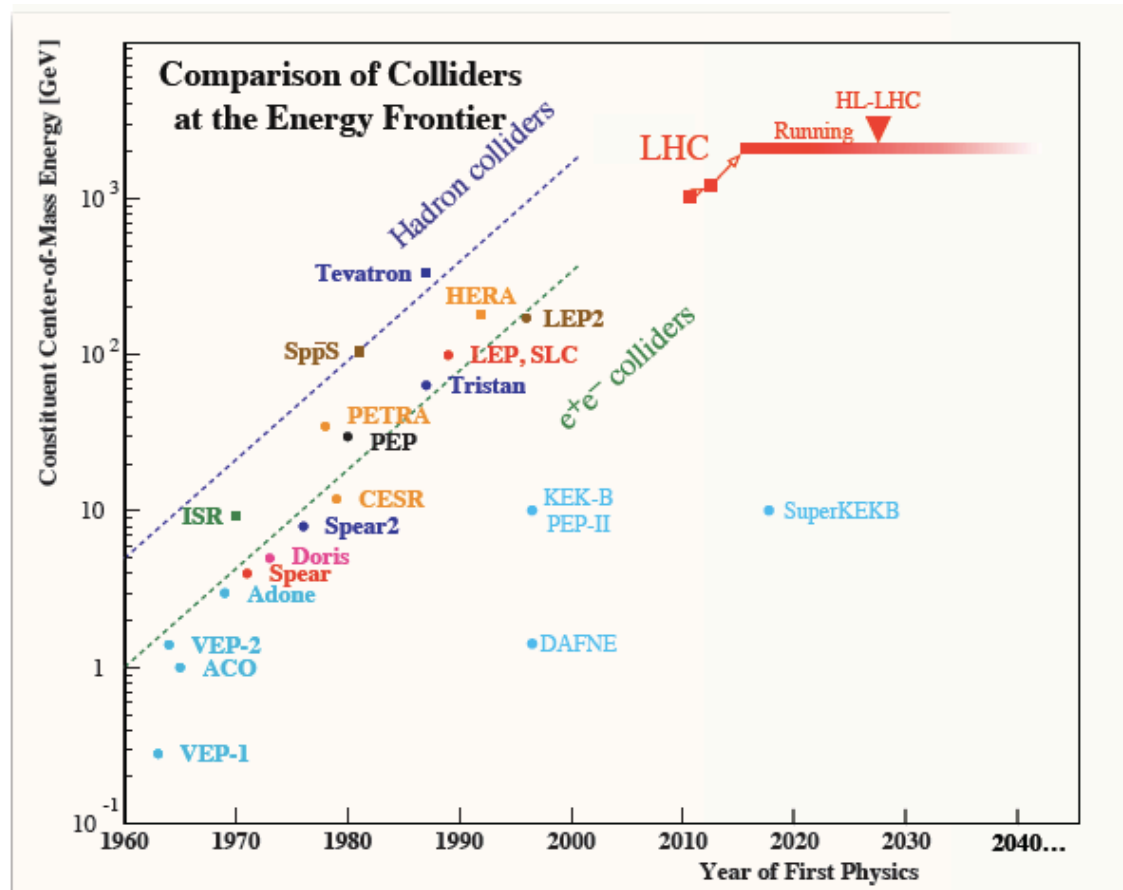

# HL-LHC

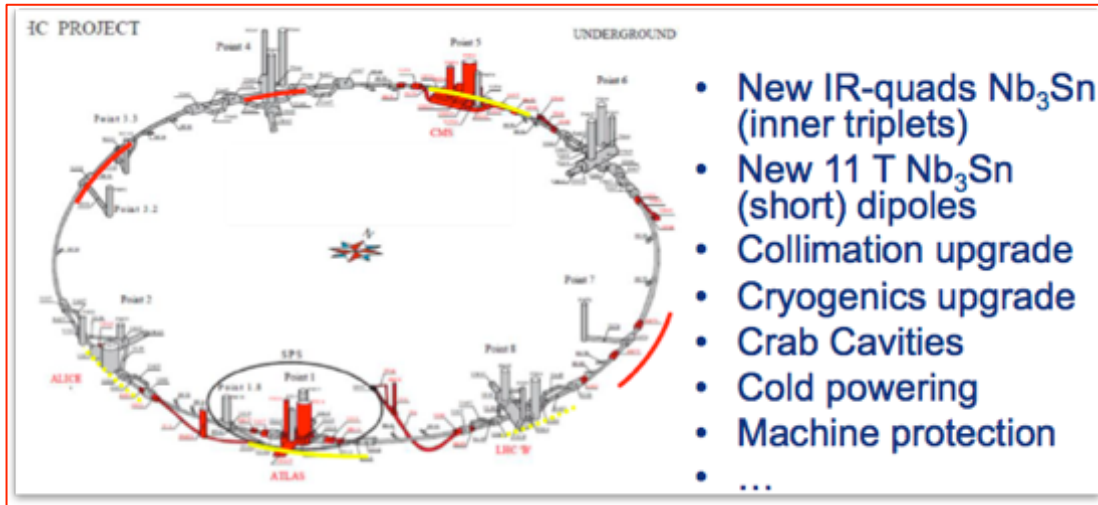

Major intervention on more than 1.2 km of the LHC

International collaboration

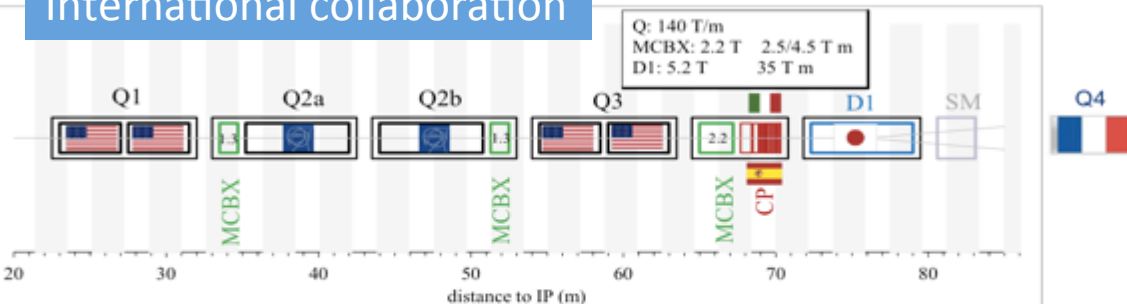

Baseline layout of HL-LHC IR region

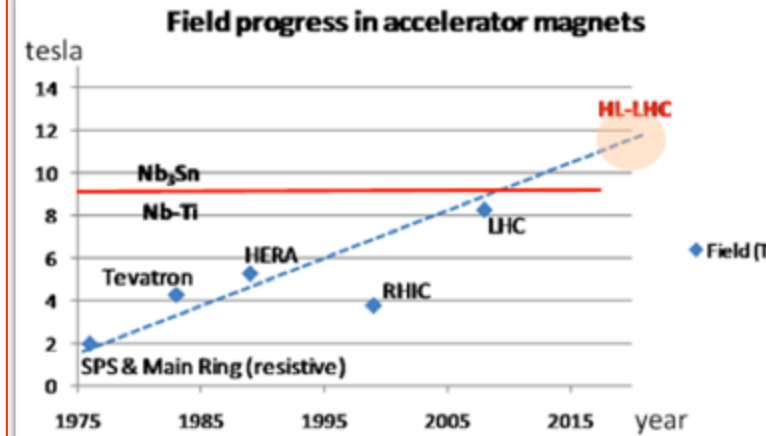

# Crab crossing

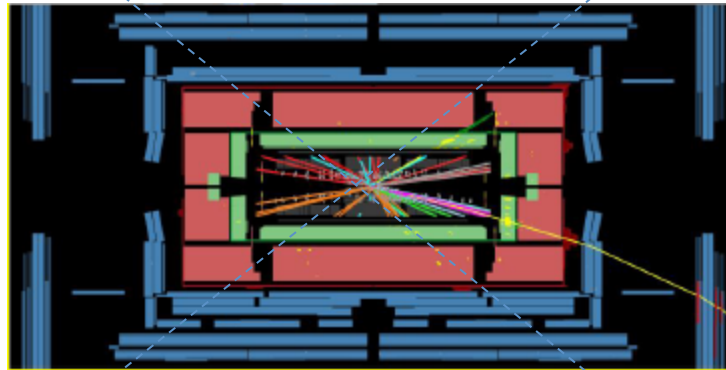

IR

4 Rod Crab  
Cavities

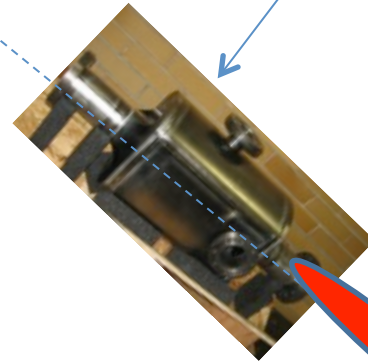
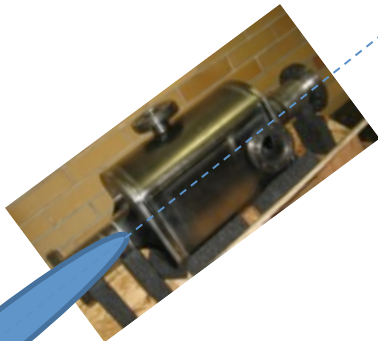
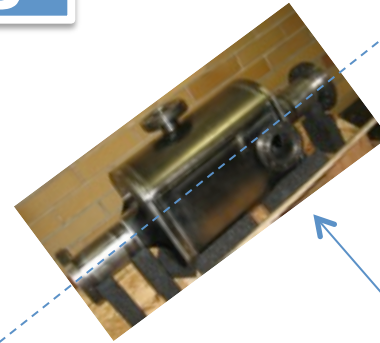
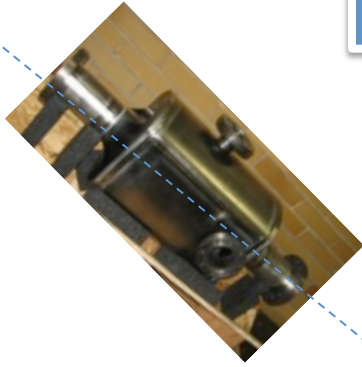



# Pile-up @ Run-1

Challenge for detectors and data analysis

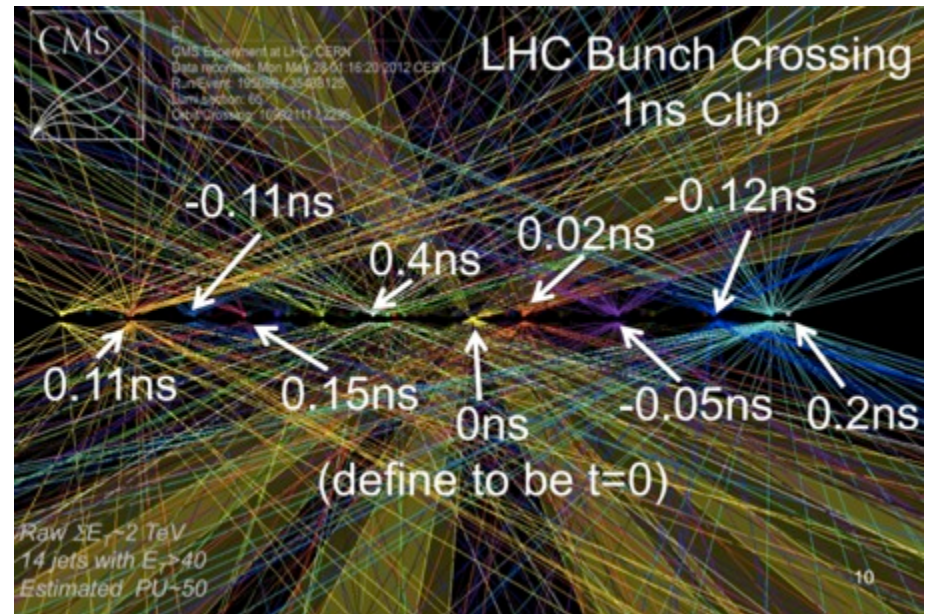
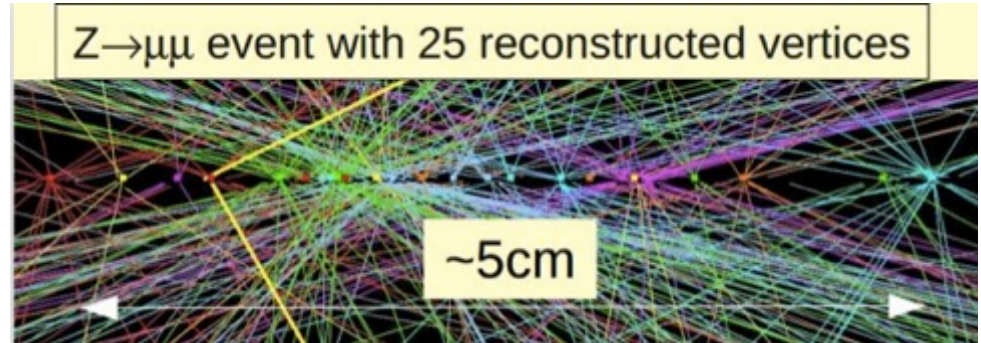
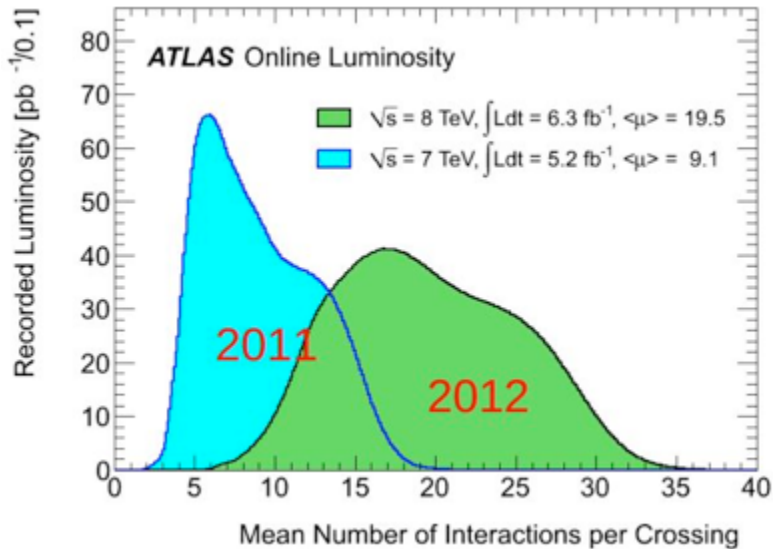

# Pile-up @ HL-LHC

Run-1

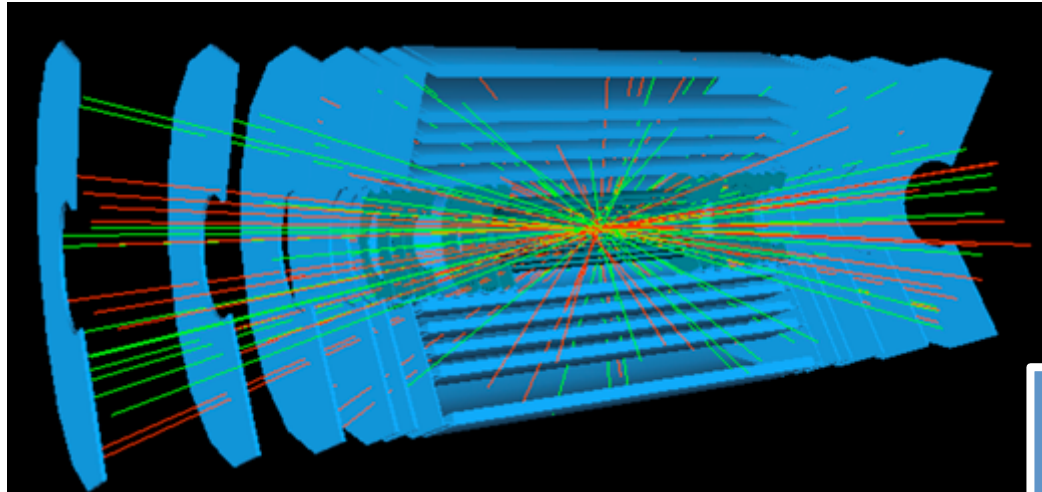

23 pile-up event

Even more challenge  
for detectors and  
data analysis

HL-LHC

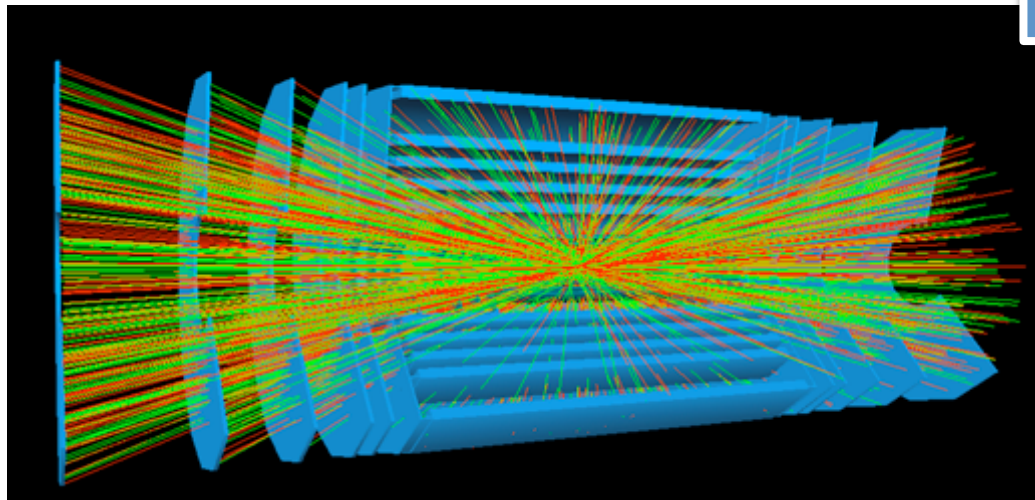

230 pile-up event



# HIGGS AT HL-LHC

Precision measurements of the Higgs sector are priority in future programme of particle physics.

## Higgs production at HL-LHC

- Over 100M Higgs bosons
- 20K  $H \rightarrow ZZ \rightarrow 4\ell\ell$
- 400K  $H \rightarrow \gamma\gamma$
- 10K  $H \rightarrow Z\gamma \rightarrow \ell\ell\gamma$

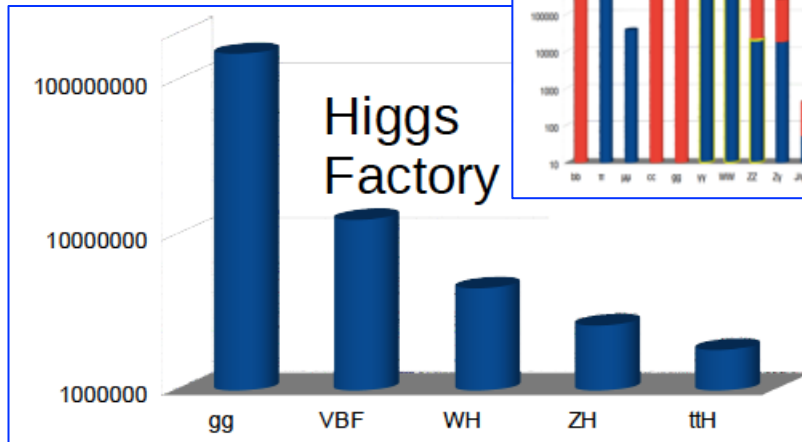

B. Murray. ECFA HL-LHC. 2013

## $(\Delta\mu/\mu)$ with $\mu = (\sigma \times BR) / (\sigma \times BR)_{SM}$

ATLAS Simulation Preliminary

$\sqrt{s} = 14$  TeV:  $\int Ldt = 300 \text{ fb}^{-1}$ ;  $\int Ldt = 3000 \text{ fb}^{-1}$

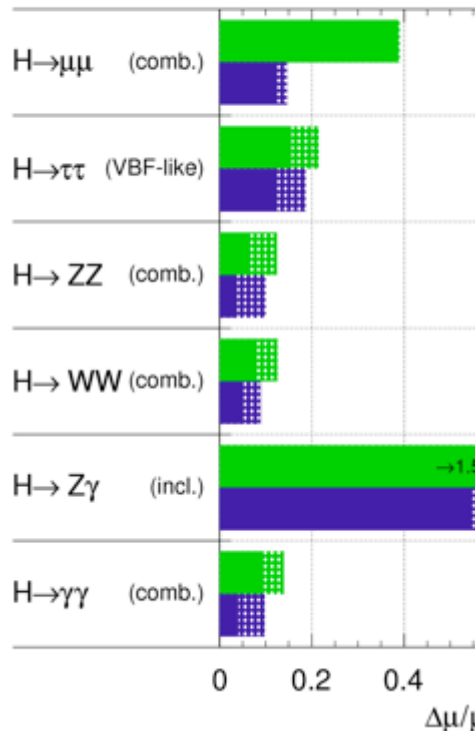

- Some channels are limited by systematic uncertainties
- Even at HL-LHC there are channels which are still highly statistic limited.

ATL-PHYS-PUB-2013-014

HL-LHC: Not the end of the Higg story

# SUSY AT HL-LHC

## Search for direct production of charginos

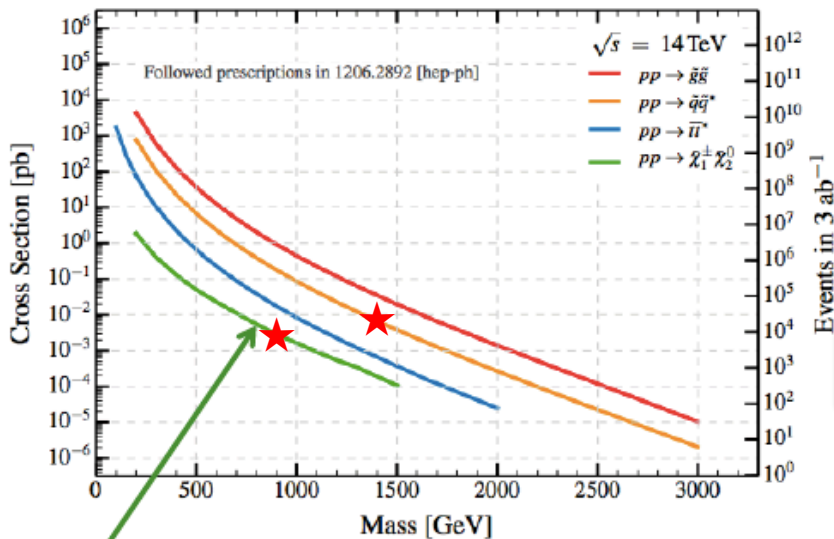

Neutralino/chargino cross sections (here assuming Wino states) are very small  
 → need high luminosity!!!

ATL-PHYS-PUB-2013-011

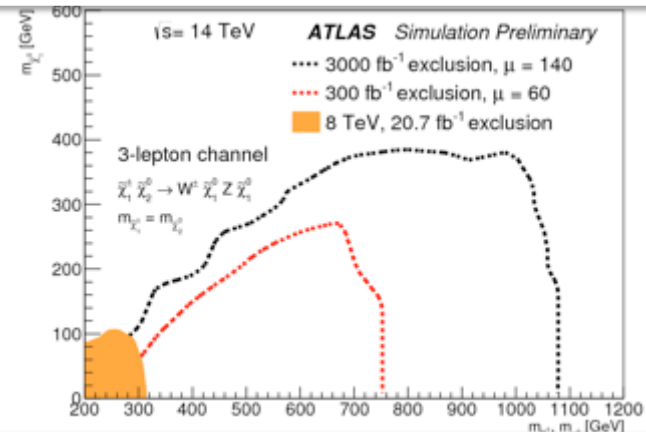

## Search for direct production of top squarks

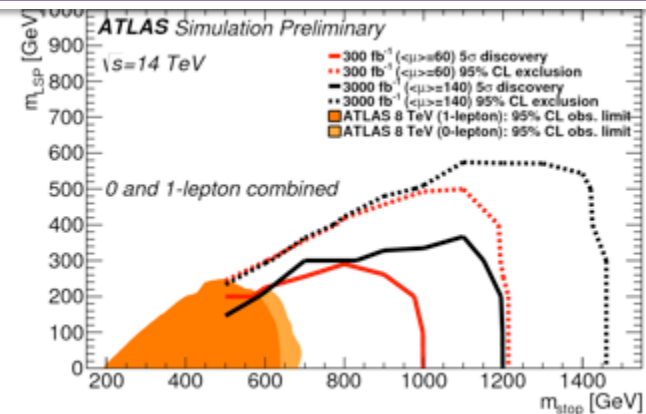

HL-LHC: Not the end of the SUSY story

# What is next?

Linear

Circular

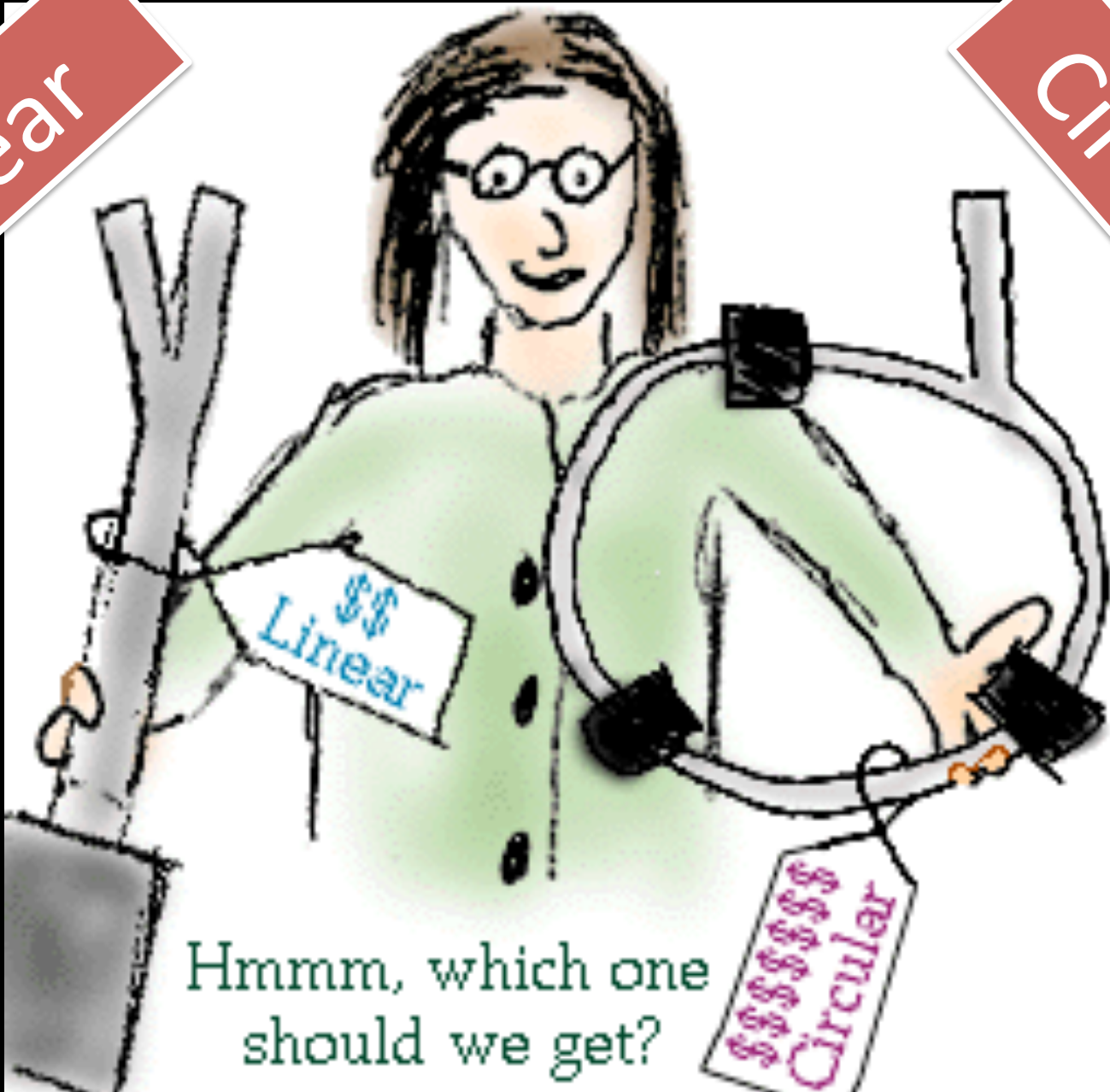

Hmmm, which one should we get?

# Synchrotrons

## IN FAVOR

- Efficient, many interaction with the same beam
- Multiple interaction points
- Accelerating systems used of each revolution of the accelerator
- Requires magnetic bending (a fact)

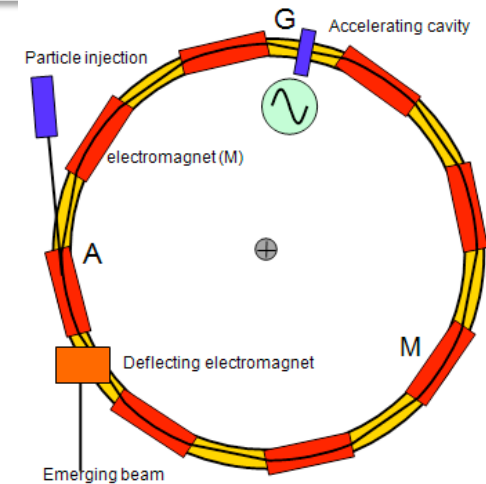
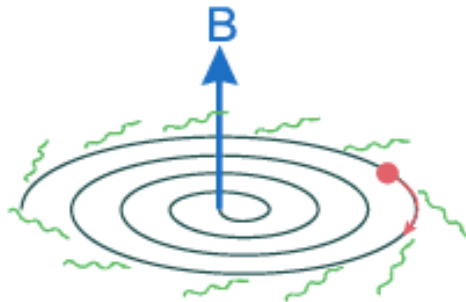

Figure 1



Loss of energy per orbit:

$$\Delta E = P \left( \frac{2\pi r}{v} \right) = \frac{4\pi K e^2 \gamma^4 \beta^3}{3r}$$

## LIMITATIONS

- Power loss due to synchrotron radiation
- Energy must be replaced by accelerator
- Higher energies also require higher luminosities

The loss rate for the electron over  $10^{13}$  times the loss for a proton of the same energy in the same synchrotron



# Linear vs Circular

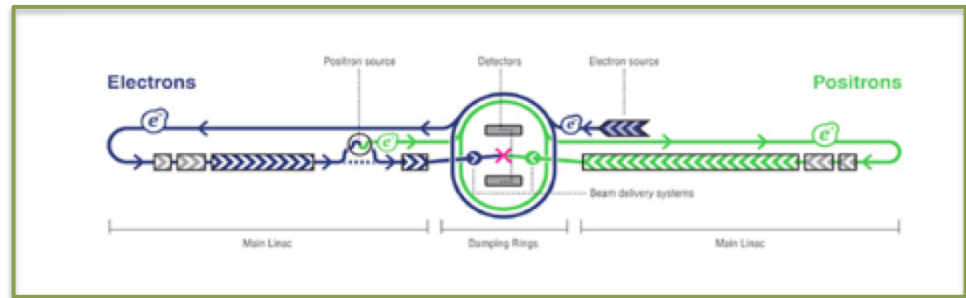

- ❑ The particles in a circular accelerator (synchrotron) go around many times, getting **multiple kicks of energy each time around**
- ❑ Synchrotrons can provide **very high-energy** particles without having to be of tremendous length.
- ❑ The particles go around many times means that there are **many chances for collisions** at those places where particle beams are made to cross.

- ❑ Much **easier to build** than circular accelerators because they don't need the large magnets.
- ❑ **Circular accelerators** also need an enormous radii in order to get particles to high enough energies, so they **are expensive to build**.
- ❑ **Less radiation loss**.
- ❑ The radiation loss is much worse for accelerating light electrons than for heavier protons. **Electrons and positrons can be brought to high energies only in linear accelerators or in circular ones with large radii.**

# Hadron vs Lepton Colliders

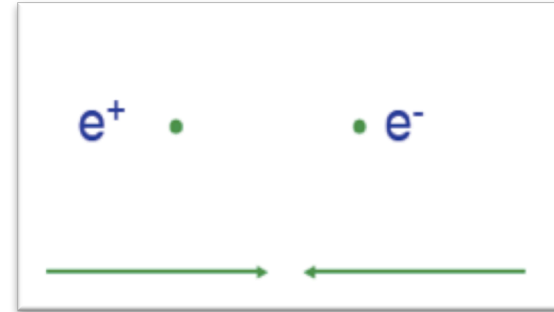
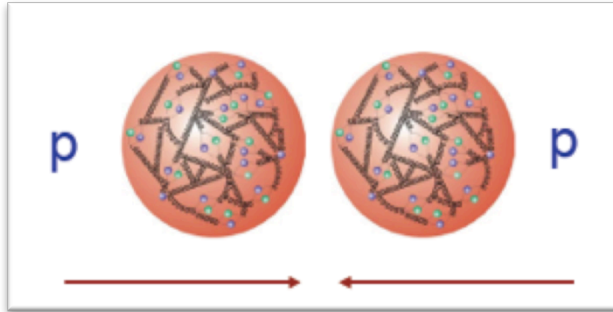

## □ **Proton (anti-) proton colliders:**

- Energy range high (limited by bending magnets power)
- Composite particles, different initial state constituents and energies in each collision
- Difficult hadronic final states

## □ **Discovery machines**

□ Precision measurement potential

## □ **Electron positron colliders:**

- Energy range limited (by RF power)
- Pointlike particles, well defined initial state quantum numbers and energies
- Easier final states

## □ **Precision machines**

□ Discovery potential

# Discovery and Precise Measurement

$$p\bar{p} \rightarrow Z^0 + X$$

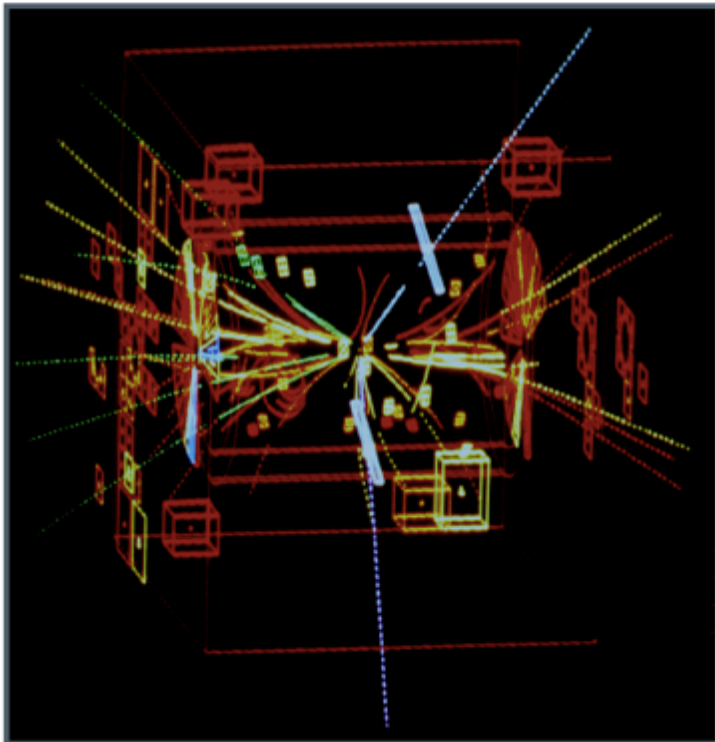

$$e^+e^- \rightarrow Z^*/\gamma \rightarrow \mu^+\mu^-$$

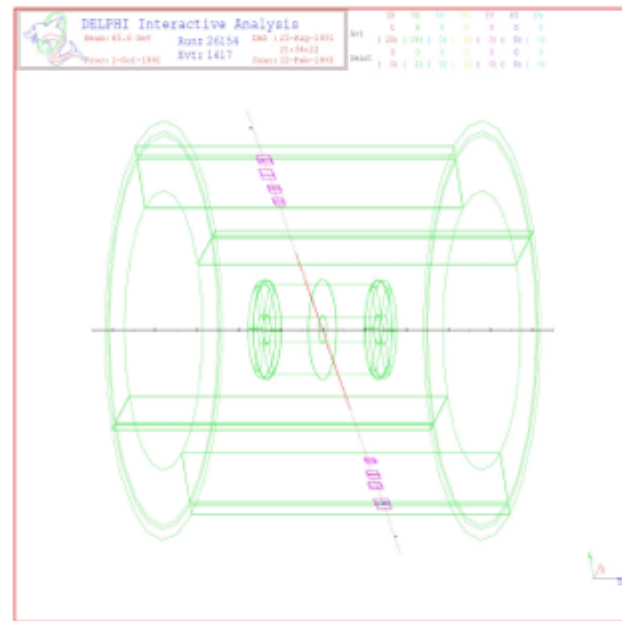

# Discovery and Precise Measurement

$$p\bar{p} \rightarrow W^\pm + X$$

$$e^+e^- \rightarrow W^+W^- \rightarrow q_1q_2 + q_3q_4$$

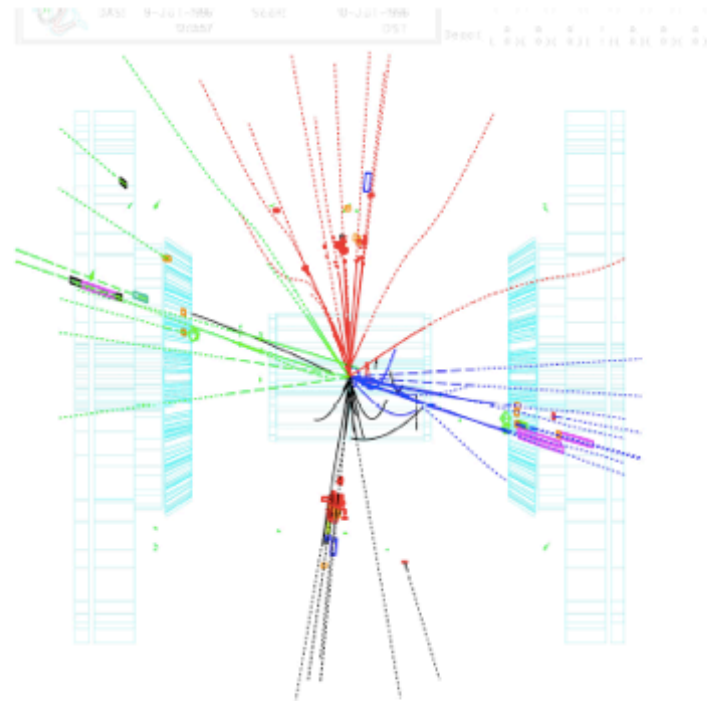
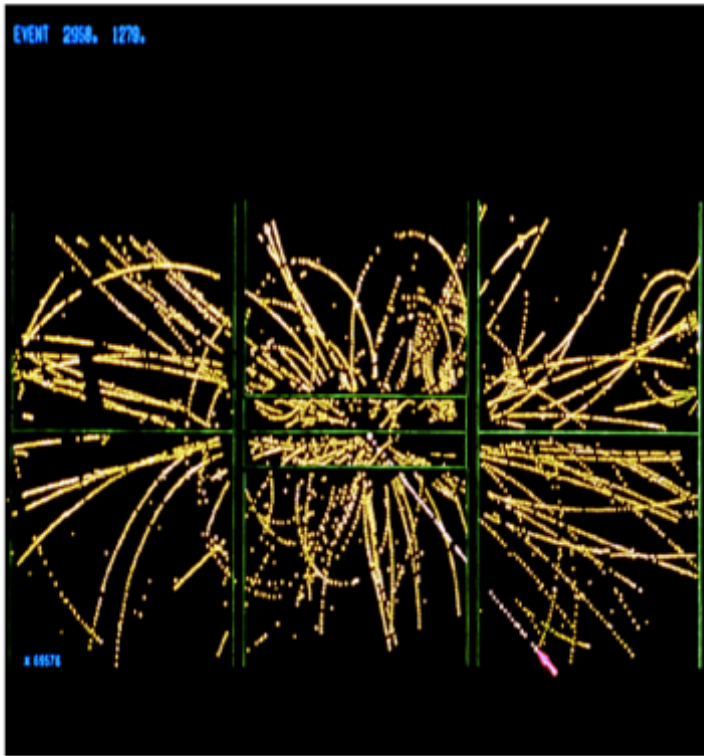

# Precision Measurements

## Pre-LEP

- Hardronic R-ratio
- Gluonic jets

## LEP I

- Z-line shape

## LEP II

- W threshold

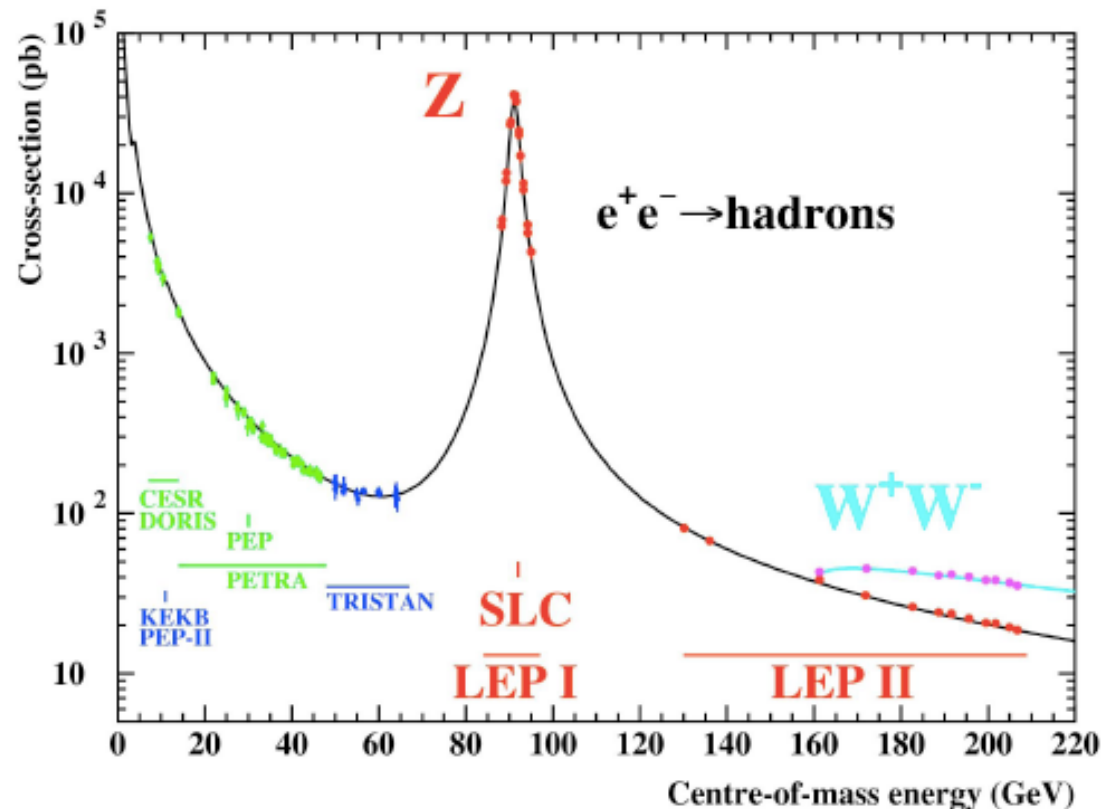



# Precision Measurements @ HLHC

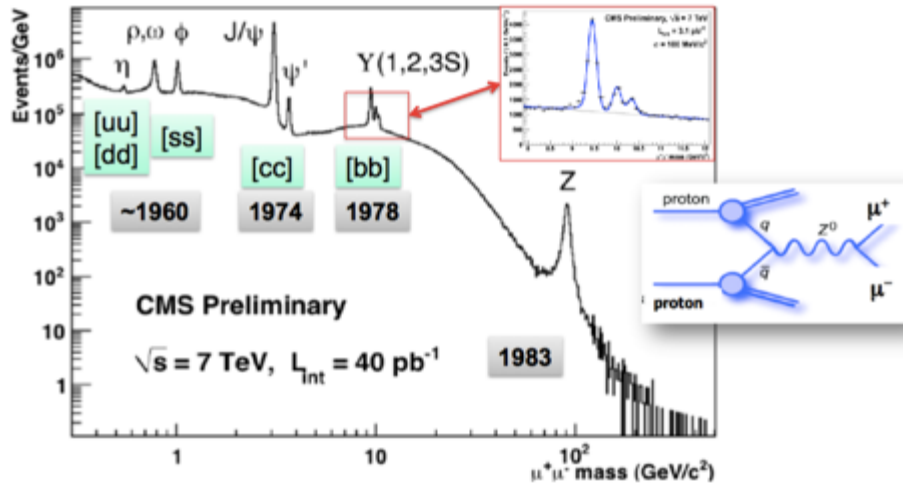

Precision is also determined by:

- High statistic
- More precise detectors
- Better analysis techniques
- More precise theoretical calculations
- ....

## Standard Model Total Production Cross Section Measurements Status: July 2014

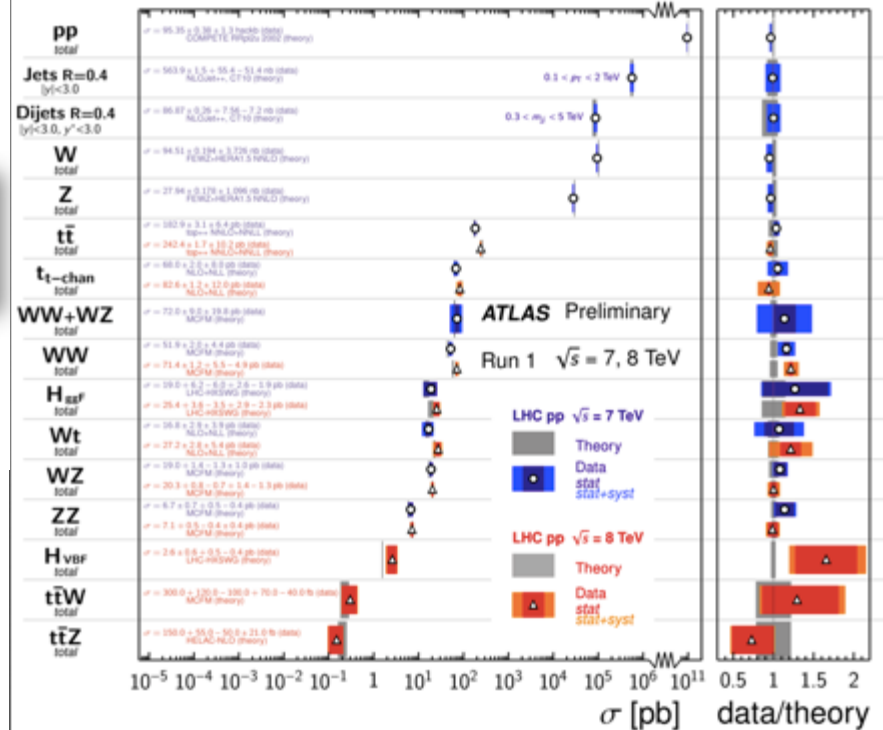

# What is next?

- LHC results vital to guide the way at the energy frontier.
- None of the future projects on the market has as strong a physics case as LHC had. Because we do not know the scale of new physics.
- The LHC Run-2 will give answer in 2018 up to the TeV scale

## New Physics: eg. Supersymmetry

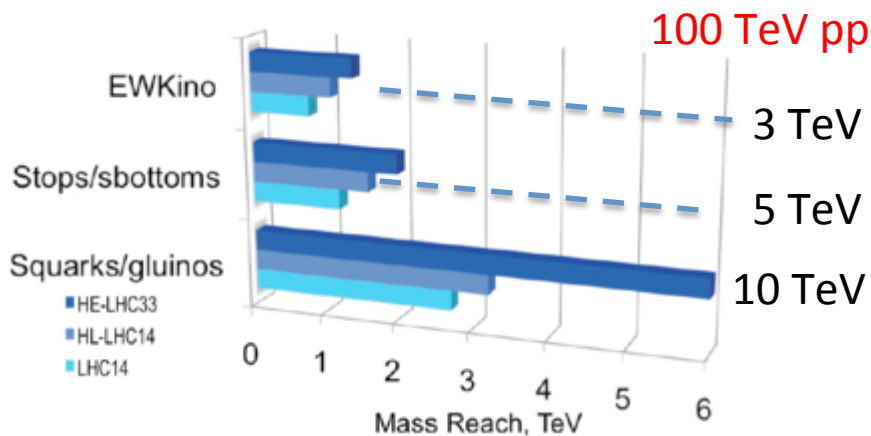

We do not see SUSY

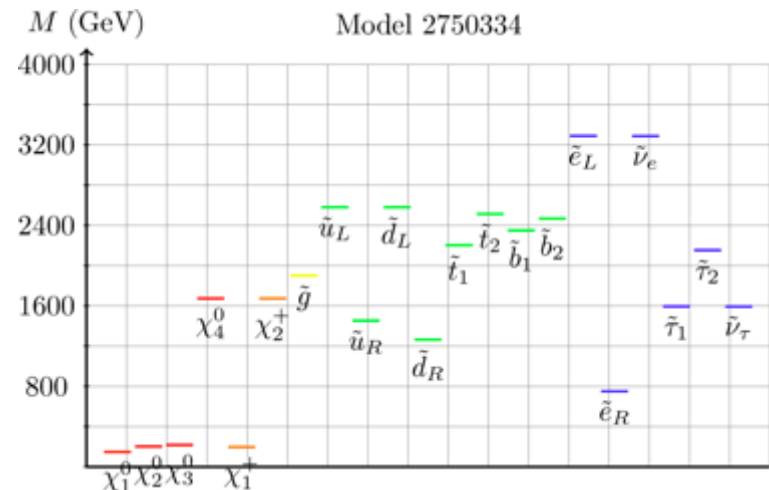

We see SUSY: gluino, light neutralinos and charginos, some squarks, but not the rest.

# Higher energies open new opportunities both pp and e+e-

pp

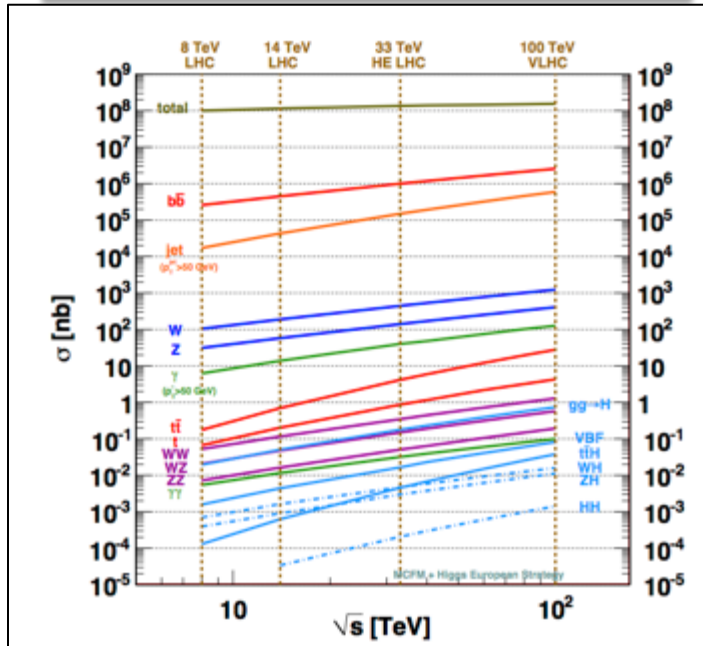

Cross-sections close to mass reach:  
 $\sigma(q^*) \sim 10^{-2} \text{ fb}$   $M \sim 50 \text{ TeV}$   
 $\sigma(Z' \rightarrow ee) \sim 4 \times 10^{-3} \text{ fb}$   $M \sim 30 \text{ TeV}$

Process	$\sigma(100 \text{ TeV})/\sigma(14 \text{ TeV})$
Total pp	1.25
W	$\sim 7$
Z	$\sim 7$
WW	$\sim 10$
ZZ	$\sim 10$
tt	$\sim 30$
H	$\sim 15$ (ttH $\sim 60$ )
HH	$\sim 40$
stop (m=1 TeV)	$\sim 10^3$

e+e-

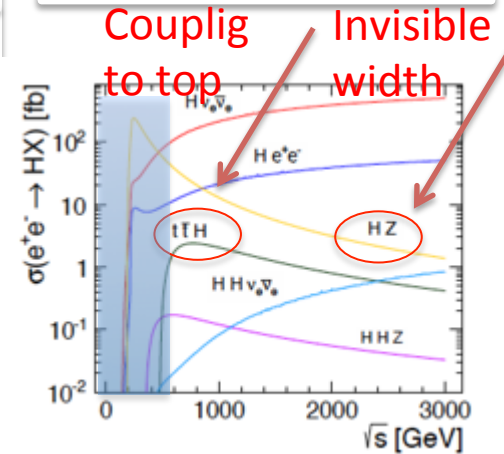

**e+e- colliders have unique advantages over a hadron machine: able to measure absolute branching fractions and couplings to more states**

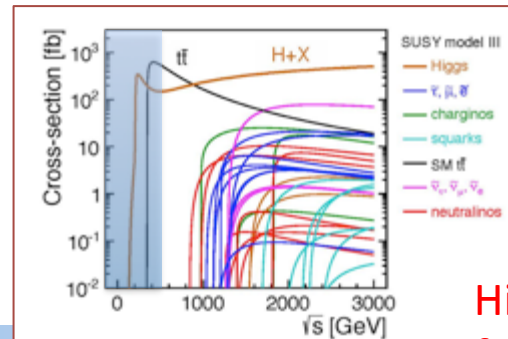

Higg and top factories

# Each supporter uses its best argument in pro of its favourite facility

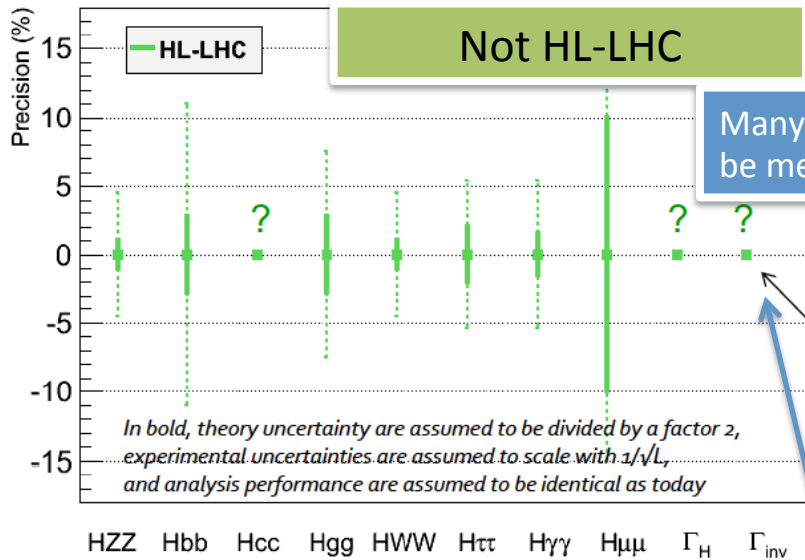

Many thinks can not be measured

1. No new decay
2.  $\Gamma_H$  fixed in the fit (or fixed BR(cc))

ATLAS upper limit at 65% (Moriond EW 2013)

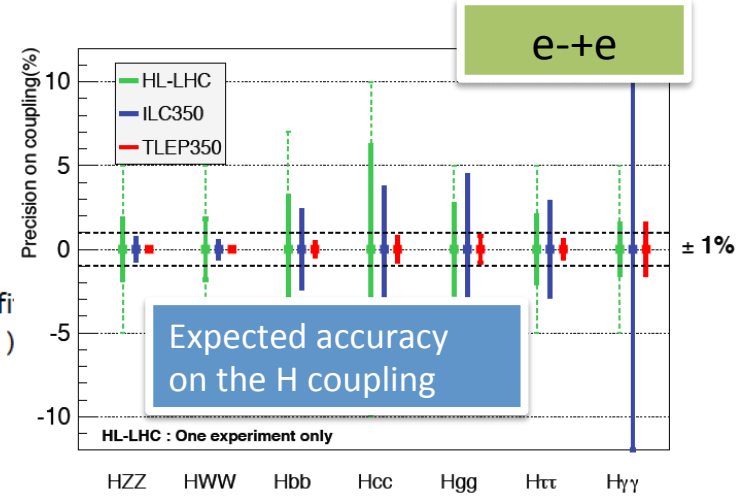

Expected accuracy on the H coupling

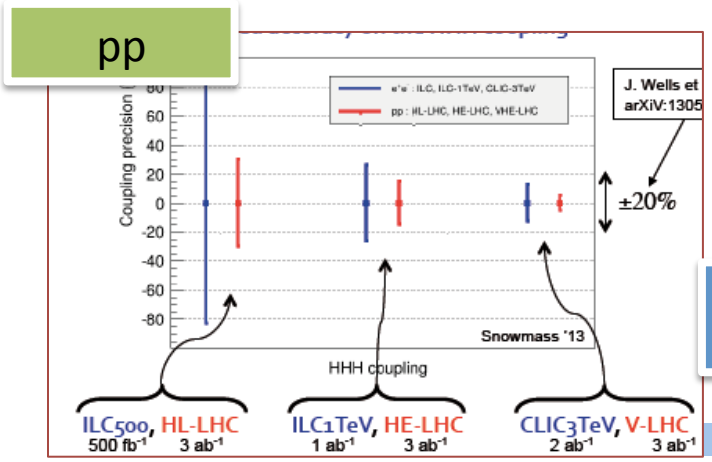

HL-LHC: (16-8%)

- ZH  $\rightarrow$  l+l + invisible
- From couplings

We have to elaborate the physics case for each facility

The facilities could be complementary

# Planned facilities

## ❖ Japon

- International Linear Collider (ILC)

## ❖ China

- Circular Electron Positron Collider (CEPC)
- Super p p Collider (SppS)

## ❖ CERN Projects

- CLIC
- HE-LHC
- FCC-pp (FCC-ee, FCC-pe)

## ❖ US

- Muon collider (not cover in this talk)



# International Linear Collider (ILC)

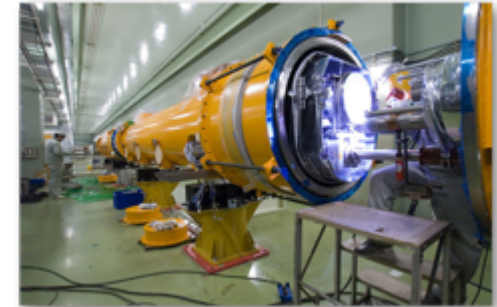
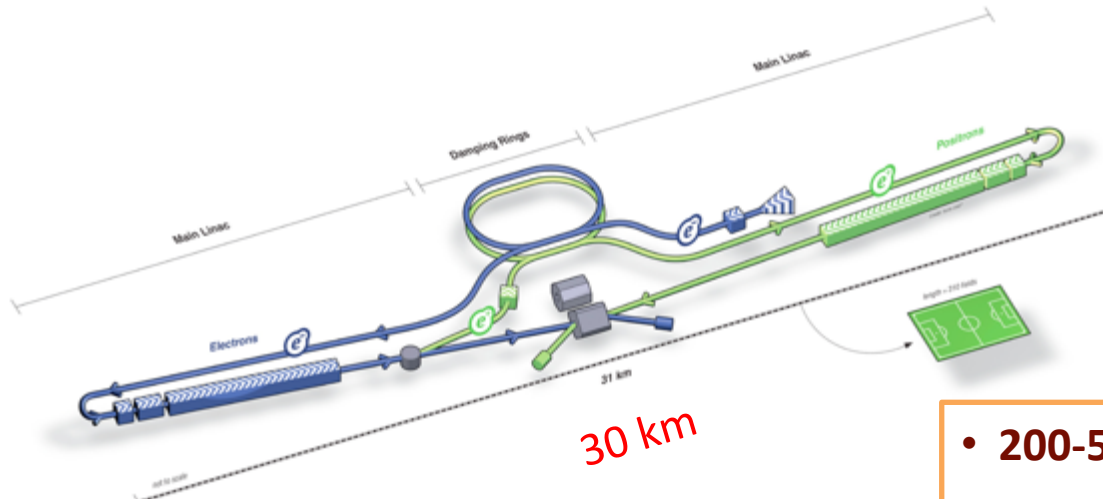

Niobium cavities



- **200-500 GeV cm (extendable to 1 TeV)**
  - $L \sim 1.8 \times 10^{34} \text{ cm}^{-2} \text{ s}^{-1}$  (@ 500 GeV)
- **SCRF Technology**
  - 1.3 GHz SCRF with 31.5 MV/m
  - 17,000 cavities
  - 1,700 cryomodules
  - 2 × 11 km linacs

# International Linear Collider (ILC)

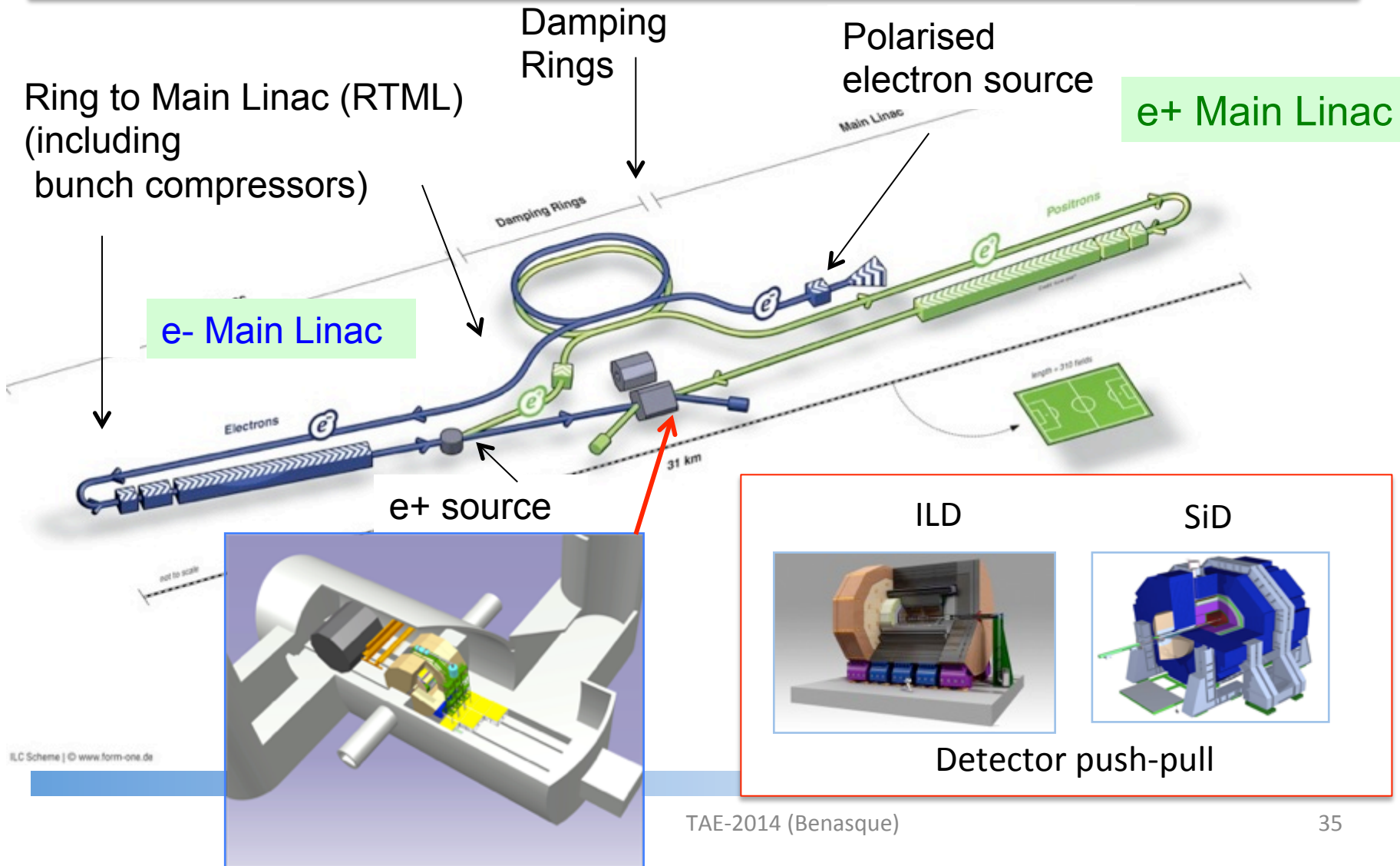

# ILC is a Global Project

Developed as a truly global collaboration with ~130 institutes  
and **>20 years R&D worldwide**

**TTF/FLASH** (DESY) ~1 GeV  
ILC-like beam ILC RF unit



DESY

INFN Frascati



**DAΦNE** (INFN Frascati)  
kicker development  
electron cloud

**STF** (KEK) operation/construction  
ILC-like Cryomodule test: S1-Gloabal  
SRF beam acceleration : QB, STF2



KEK, Japan



**ATF & ATF2** (KEK)  
ultra-low emittance  
Final Focus optics, nano-beam  
**KEKB** electron-cloud



**CesrTA** (Cornell)  
electron cloud  
low emittance

Cornell

FNAL



**NML/ASTA facility**  
ILC RF unit test  
Full-CM Test,  
SRF beam acceleration, soon

2013



# ILC is a Global Project

US and EU (industrial) production and test capacity.  
Perfectly placed for start of ILC construction end of this decade.





# ILC is a Global Project

US and EU (industrial) production and test capacity.  
Perfectly placed for start of ILC construction end of this decade.

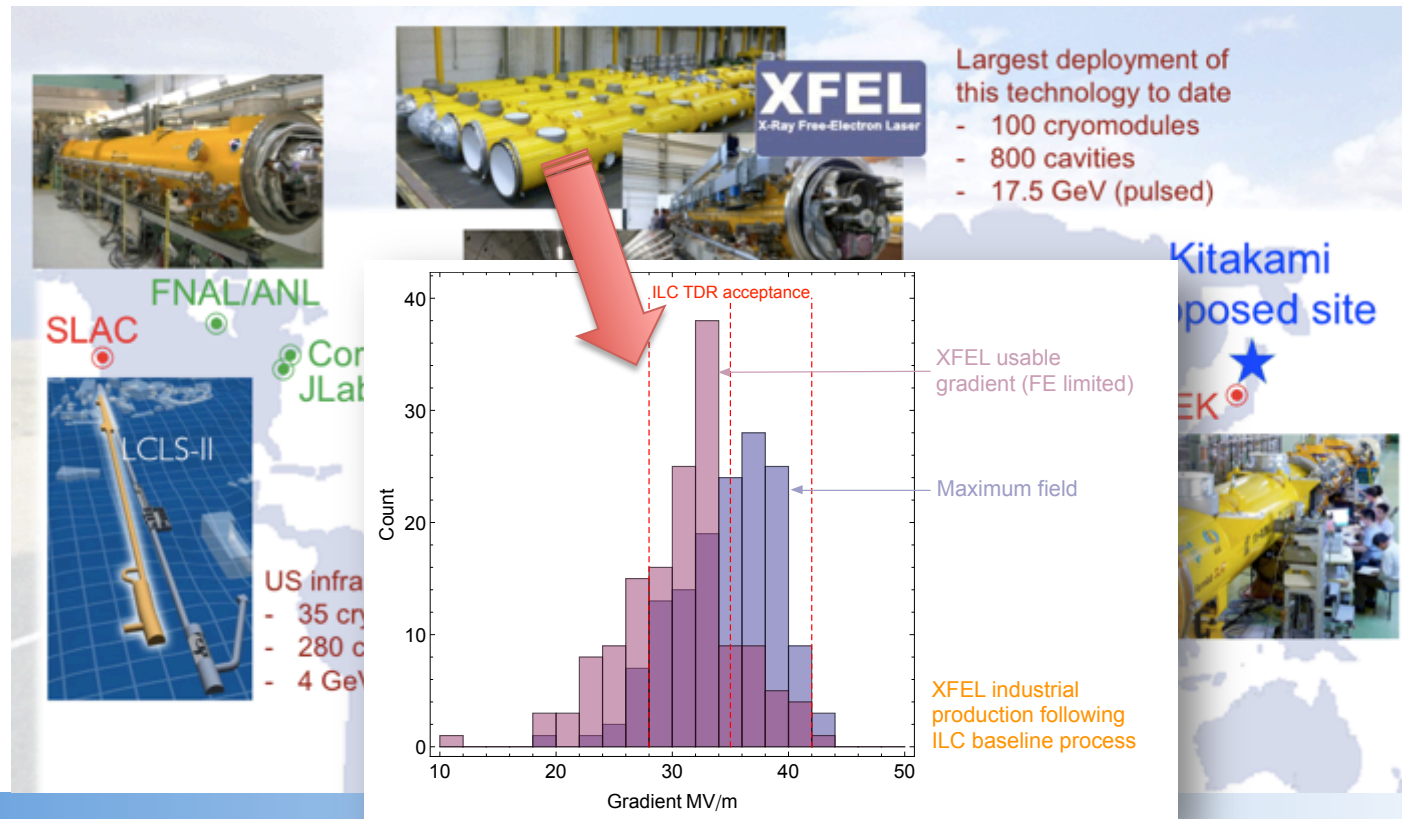

# ILC in JAPAN



- Japanese government express interest to host ILC s an **international project**
- Initiative is welcomed in the HEP strategies of the US and Europe
- Japan has selected a potential site for the ILC in **Kitakami**

Safe from earthquake

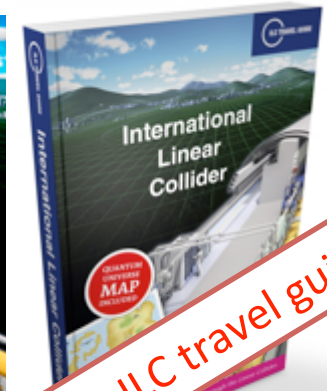
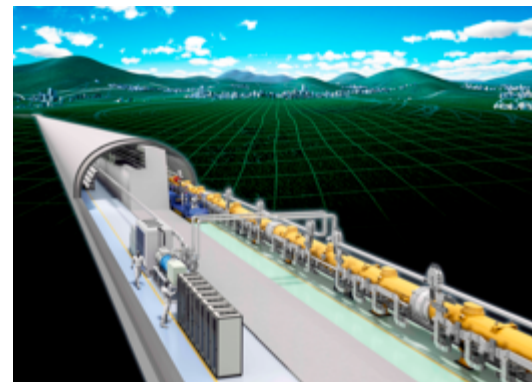
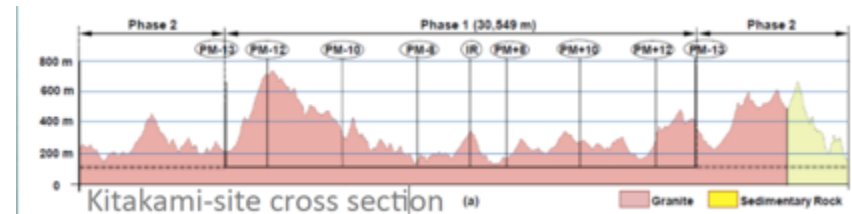

The ILC travel guide



# ILC in JAPAN



- Japanese government express interest to host ILC s an **international project**
- Initiative is welcomed in the HEP strategies of the ILC **type**
- Japan has selected a potential site for the ILC in **from earthquake**

## ILC Candidate site in Kitakami, Tohoku

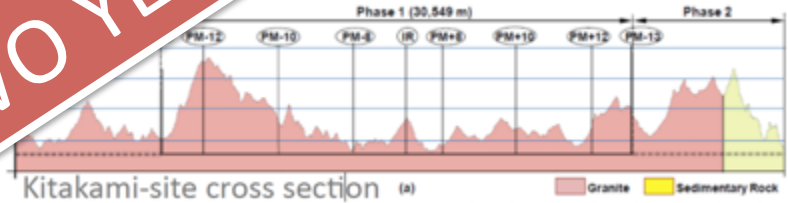

**DECISION IN TWO YEARS**

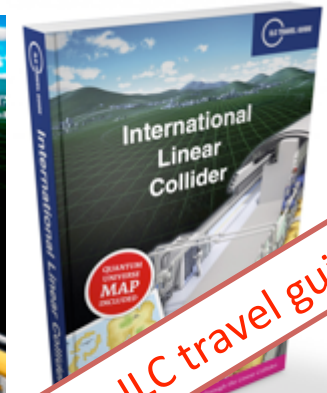
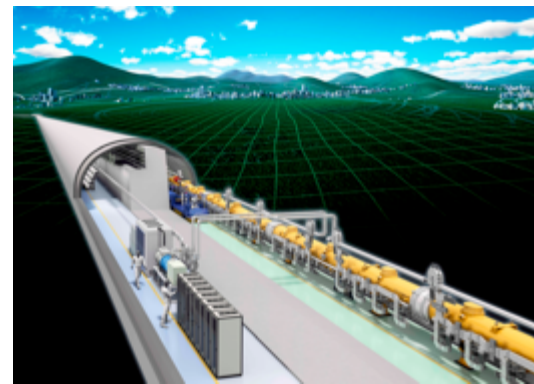

**The ILC travel guide**

# ILC is just a Budget question

## Table 1 Summary of Scenarios

Project/Activity	Scenarios			Science Drivers					Technique (Frontier)
	Few money Scenario A	A bit of money Scenario B	A lot of money Scenario C	Higgs	Neutrinos	Dark Matter	Cosm. Accel.	The Unknown	
<b>Large Projects</b>									
Muon program: Mu2e, Muon g-2	Y, <small>Mu2e small reprofile needed</small>	Y	Y					✓	I
HL-LHC	Y	Y	Y	✓		✓		✓	E
LBNF + PIP-II	Y, <small>LBNF components delayed relative to Scenario B</small>	Y	Y, enhanced		✓			✓	I,C
ILC	R&D only	R&D, <small>possibly small hardware contributions. See text.</small>	Y	✓		✓		✓	E
NuSTORM	N	N	N		✓				I
RADAR	N	N	N		✓				I

# The CLIC project

- Double beam acceleration, up to  $\sim 3$  TeV,  $\sim 10^{34} \text{cm}^{-2}\text{s}^{-1}$
- With different phases.
- Very large gradients :  
80 MV/m - 100MV/m
- With an affordable cost !!!

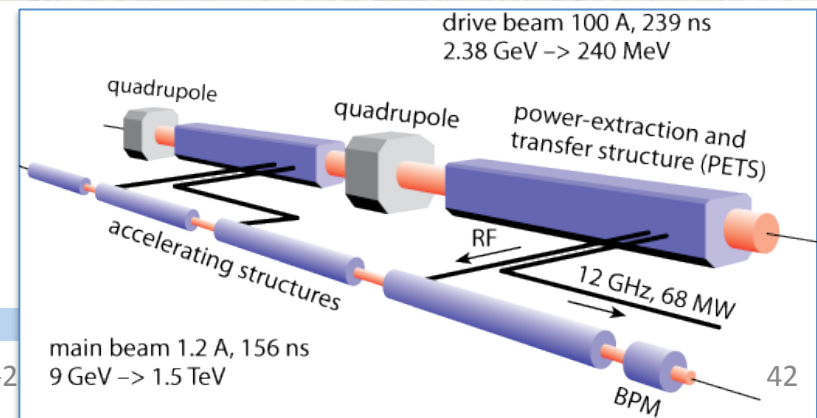
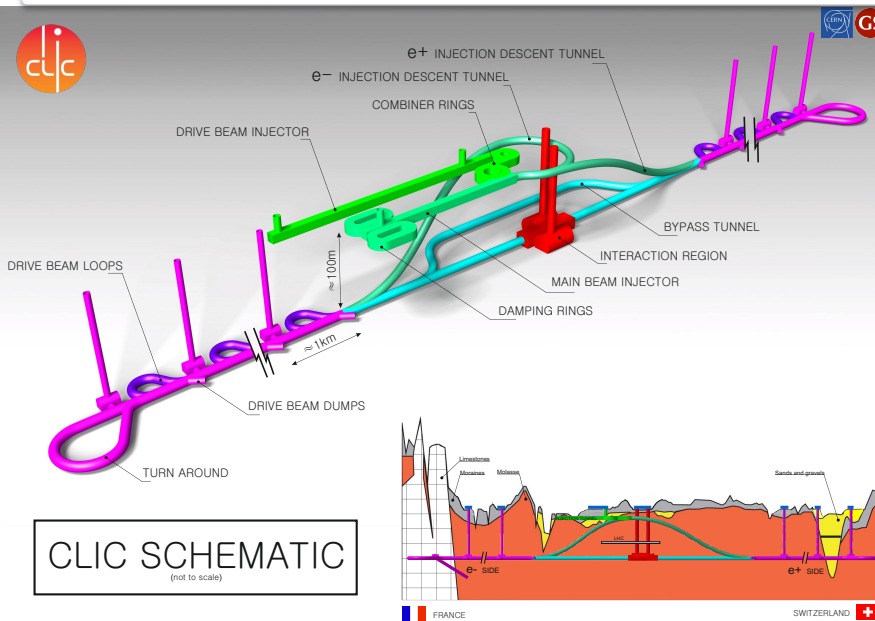
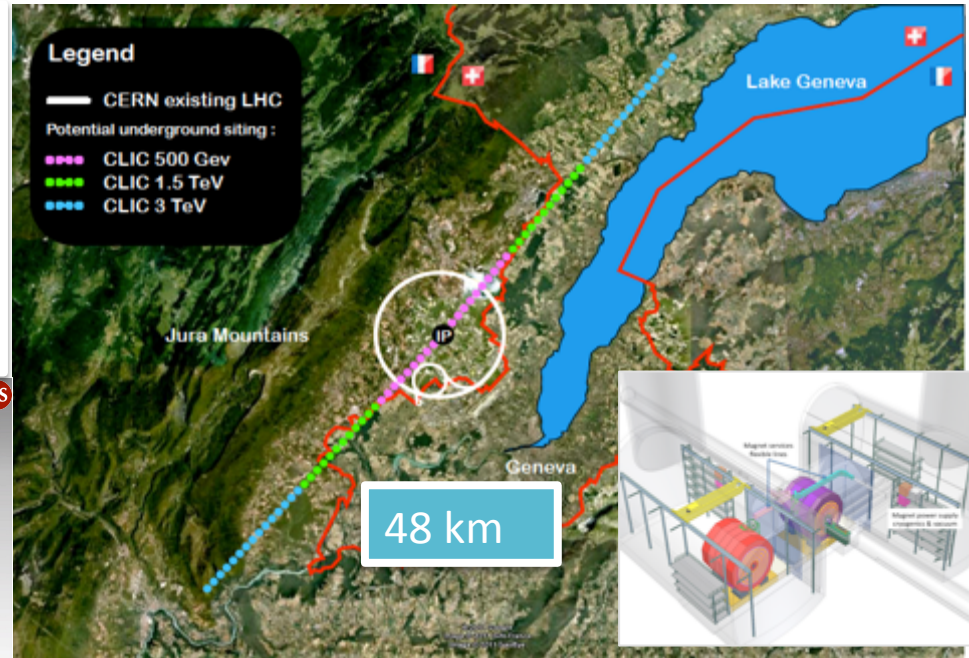

Carmen García

TAE-2

# The CLIC project

## CLIC frequency multiplication mechanism

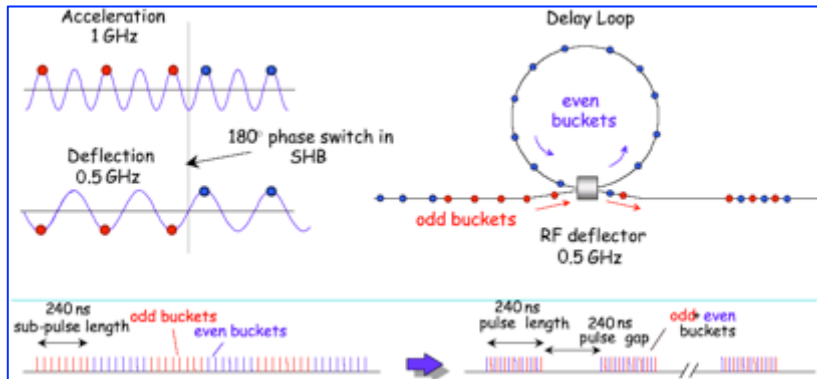

## Power Extraction and Transfer Structures

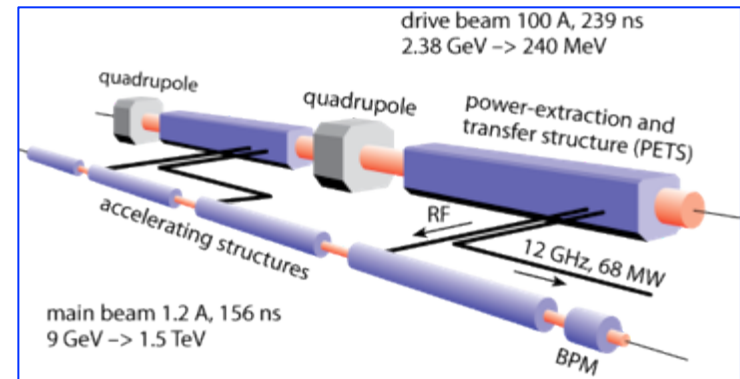

## CLIC detectors, push-pull system

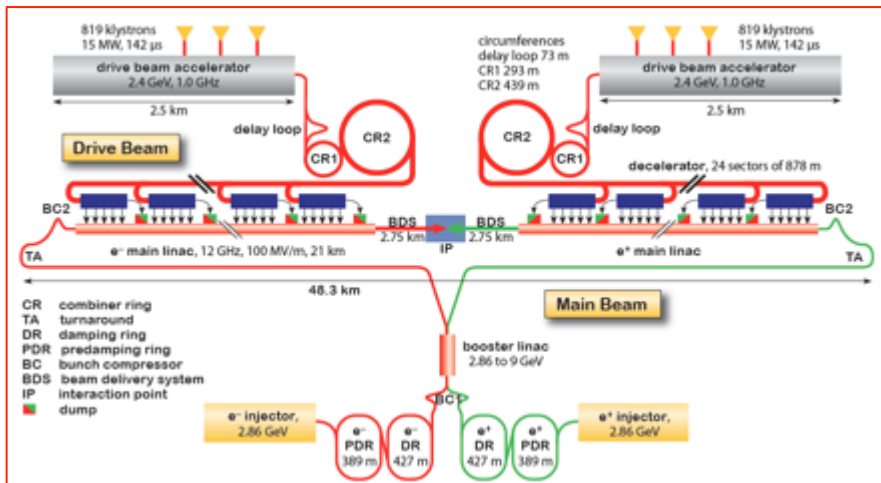
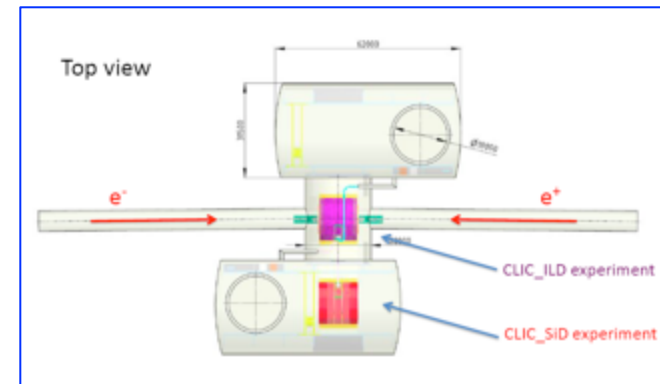



# Still many R&D required to be ready for construction

## 2013-18 Development Phase

Develop a Project Plan for a staged implementation in agreement with LHC findings; further **technical developments with industry**, performance studies for accelerator parts and systems, as well as for detectors.

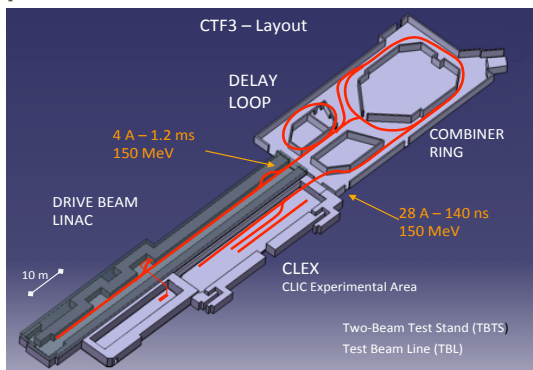

## 2018-19 Decisions

On the basis of LHC data and Project Plans (for CLIC and other potential projects as FCC), **take decisions about next project(s) at the Energy Frontier.**

## 4-5 year Preparation Phase

Finalise implementation parameters, Drive Beam Facility and other system verifications, site authorisation and preparation for industrial procurement.

Prepare **detailed Technical Proposals** for the detector-systems.

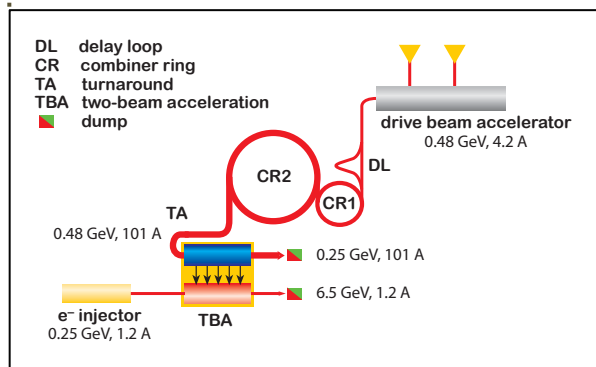

## 2024-25 Construction Start

**Ready for full construction and main tunnel excavation.**

## Construction Phase

Stage 1 construction of CLIC, in parallel with detector construction.

Preparation for implementation of further stages.

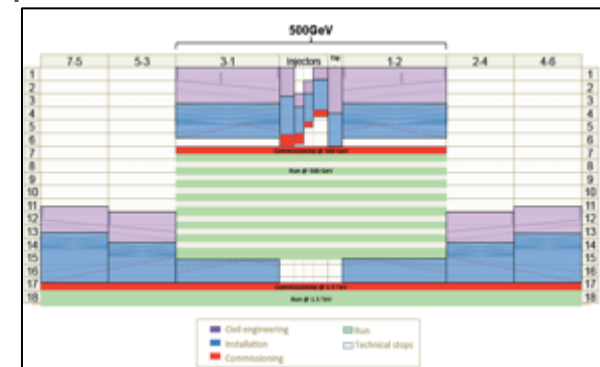

## Commissioning

Becoming ready for data-taking as the LHC programme reaches completion.



# CLIC Collaboration



29 Countries – over 70 Institutes



- Accelerator collaboration
- Detector collaboration
- Accelerator + Detector collaboration

Detector collaboration operative with 23 institutes





# Evolution of Colliders - the future?

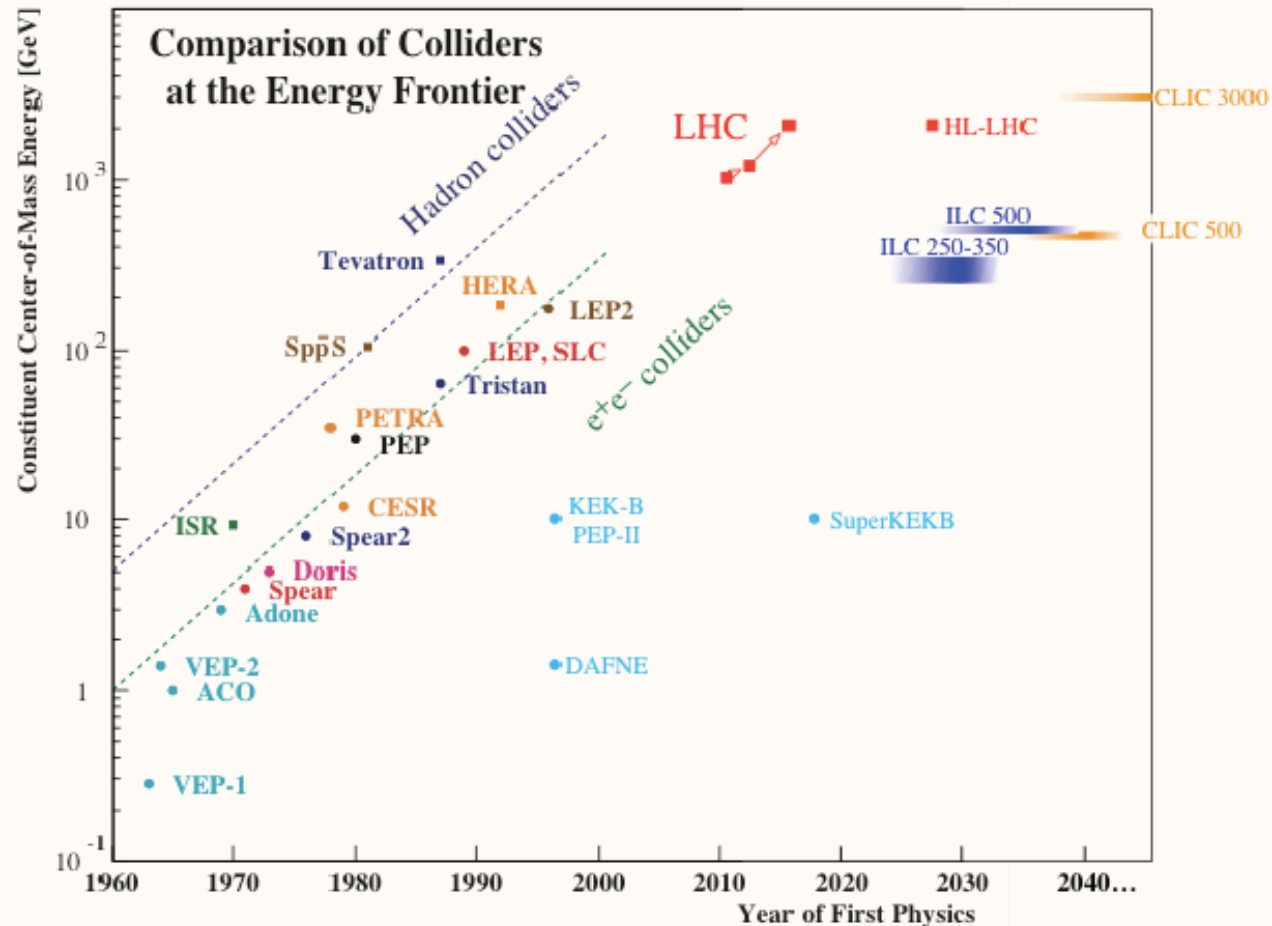

N. Walker

# What's happening in China ?

- Starting in the last 2 years but things are happening fast since then
- Established “Center for Future High Energy Physics” (CFHEP)



- **Circular Higgs factory (phase I) + super pp collider (phase II) in the same tunnel**

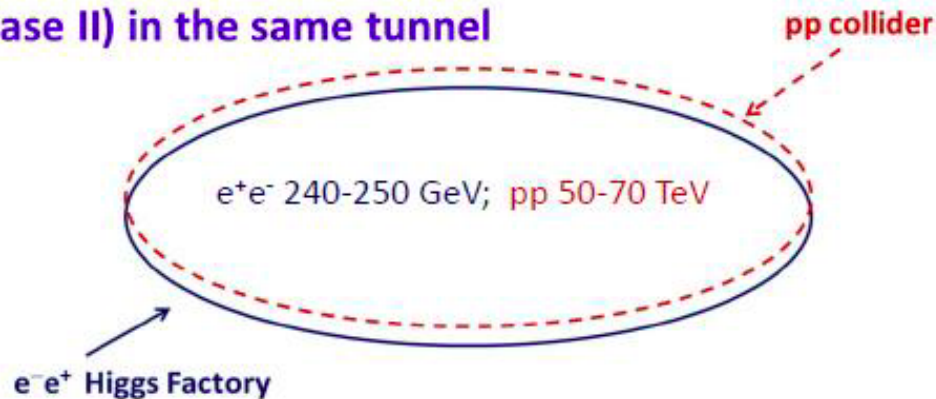

- Under consideration now:
- Circular Electron Positron Collider (CEPC).
  - Super Proton Proton Collider (SPPC)

# CpeC and SppC road map

## CpeC

- Pre-study, R&D and preparation work
  - Pre-study: 2013-15
  - R&D and funding request 2014
  - R&D: 2016-2020
- Engineering Design: 2015-2020
- **Construction: 2021-2027**
- **Data taking: 2028-2035** ← **HL-LHC**

## SppC

- Pre-study, R&D and preparation work
  - Pre-study: 2013-2020
  - R&D: 2020-2030
  - Engineering Design: 2030-2035
- **Construction: 2035-2042**
- **Data taking: 2042 -**



# Recent CERN Initiative: FCC

Study effort initiated by CERN, based on 80-100 km tunnel, with a primary goal for 100 TeV pp collider (FCC-hh). The tunnel could accommodate 350 GeV e+e- (FCC-ee), and ep colliders (FCC-ep).

intermediate step



Studies of viability for the next European Strategy in 2018



# FCC-hh: a proton-proton Collider

## FCC-hh

In a 80 km tunnel

- **42 TeV** with 8.3T LHC magnets
- **80 TeV** with 16T Nb<sub>3</sub>Sn magnets
- **100 TeV** with 20T HTS magnets

In a 100 km tunnel

- **100 TeV** with 16T Nb<sub>3</sub>Sn magnets

Programme of the design study

- Demonstrate 16T performance
- Develop 20T concepts

**HE-LHC: 33TeV with 20T magnets**

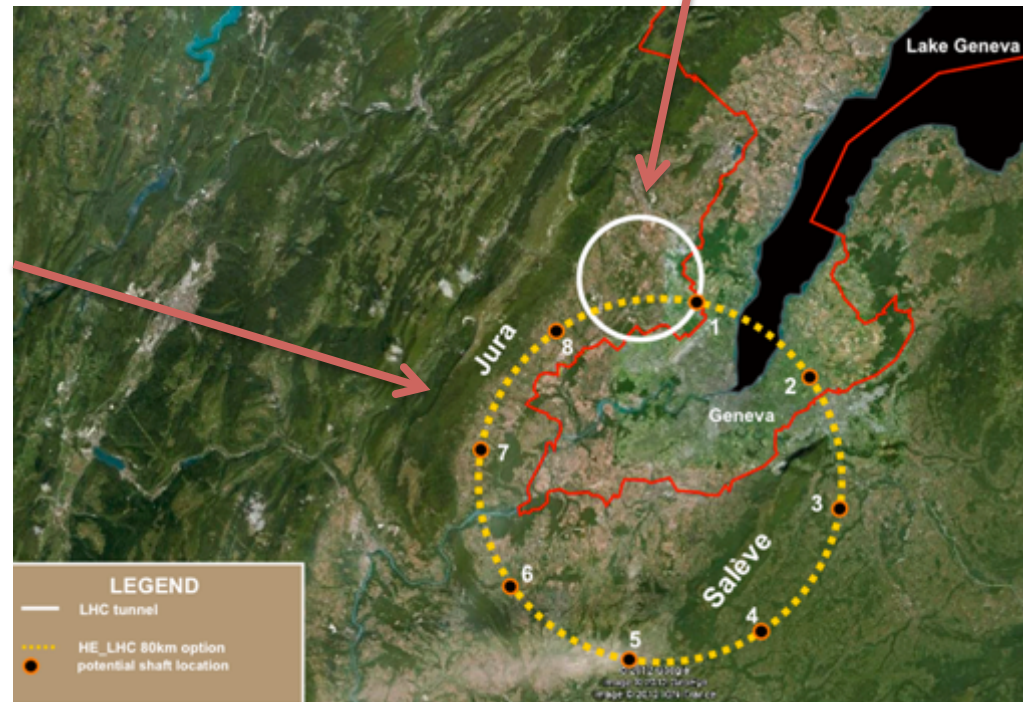

# The Magnet Challenge

Is it really possible to go so high?

R&D needed to bring the cost down

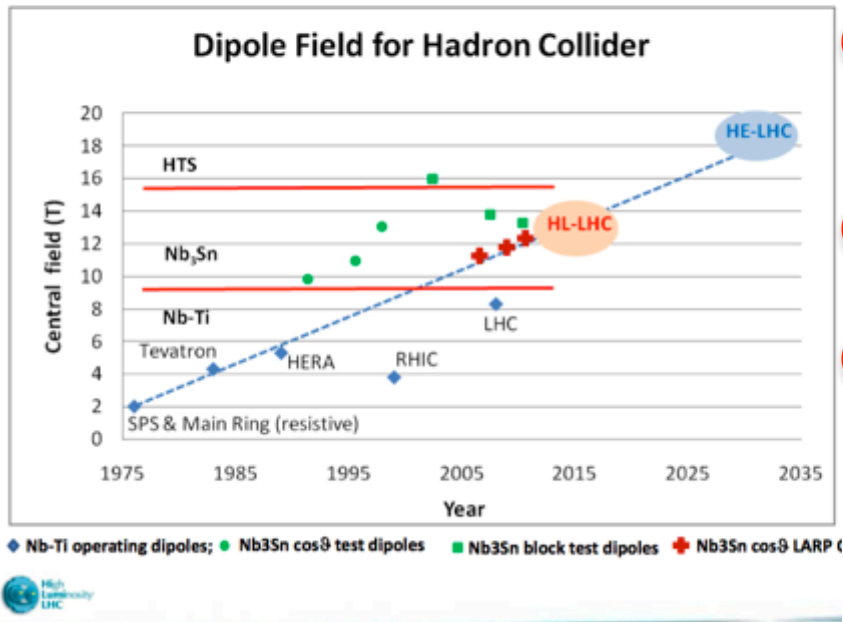

- HTS (SF, 35 K)
- MgB<sub>2</sub> (SF, 25 K)
- Nb<sub>3</sub>Sn (12 T, 4.2 K)
- Nb-Ti (5 T, 4.2 K)

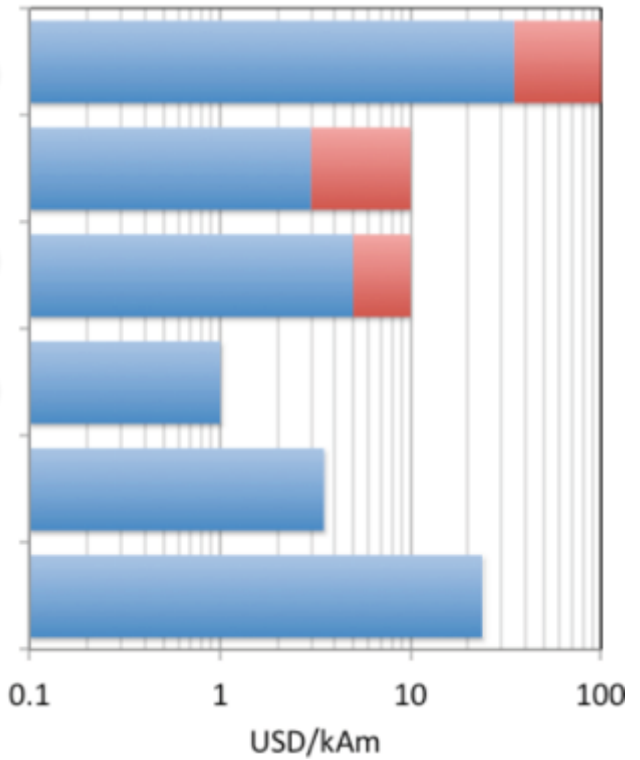



# FCC-ee: the Electron-Positron Option

- Circular e<sup>+</sup>e<sup>-</sup> collider with  $\sqrt{s}$  energy in the range of 90-350 GeV
- Can serve 4 experiments simultaneously
- Challenging but no showstoppers!! (2 rings)
- Energy loss/turn  $\sim 11$  GeV

- ❑ In July 2011 a proposal was made to (re)install a 120 GeV / beam e<sup>+</sup>e<sup>-</sup> collider in the LEP-LHC tunnel – named LEP3. Work on LEP3 started in a series of workshops.
- ❑ The 80 km TLEP machine appeared in 2012 in parallel with the feasibility study for a 80 km ring for a future hadron collider around CERN. TLEP and LEP3 were presented in September 2012 at the European Strategy meeting in Krakow.
- ❑ In October 2013 TLEP was integrated into the FCC study and is now known as FCC-ee.

The idea has been around for a long time

# The Power Challenge

For lepton machines:  
high luminosity means  
high power consumption

- for comparison LHC machine <100 MW
- high power means high running costs...

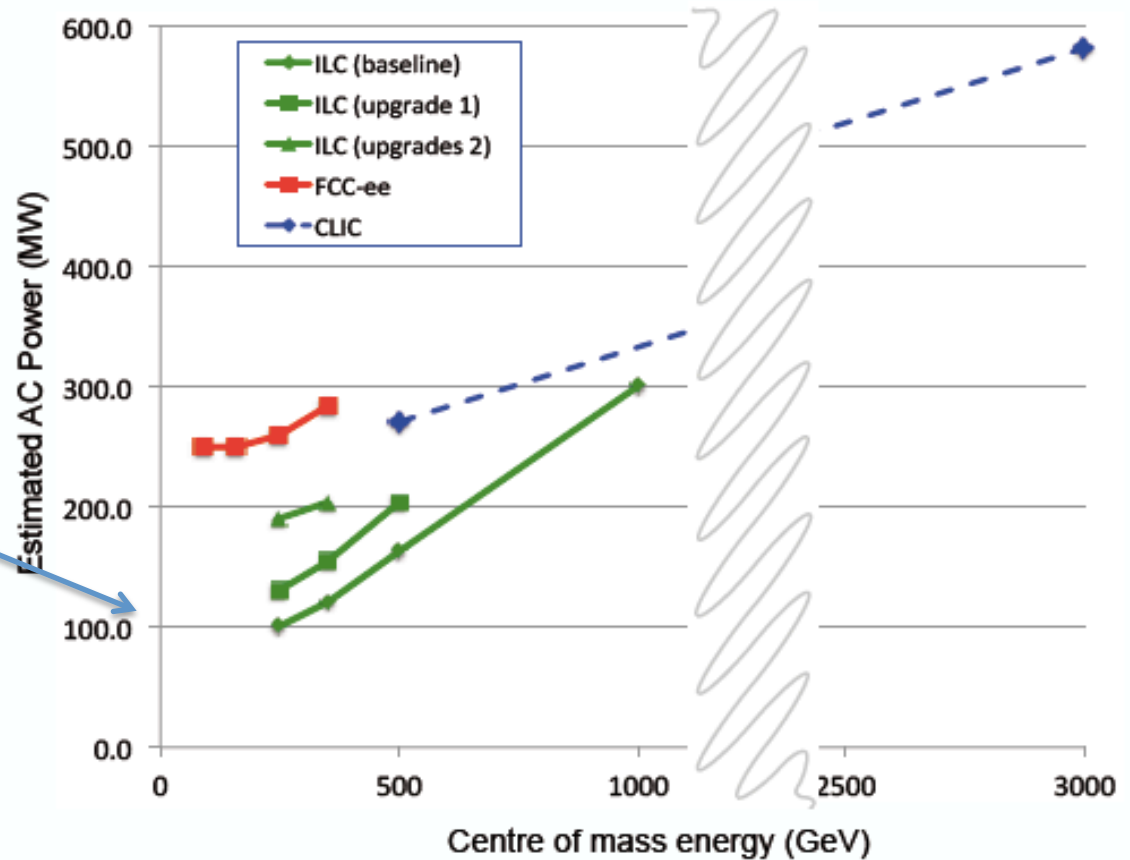

# What is next at CERN ?

- Studies for next ES (2018)
- LHC results to point the way
- Global context

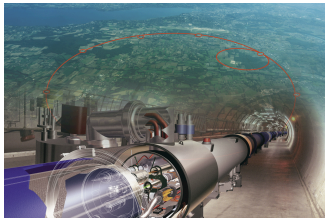

2035+ ?

Beyond LHC

HE-LHC

- pp 33 TeV CM
- 20 T dipoles (HTS tech.)
- $\mathcal{L} \sim 2 \times 10^{34}$



CLIC

- e+e- 500 - 3000 GeV
- x-band accelerator technology
- 2-beam acceleration
- $\mathcal{L} \sim 2-6 \times 10^{34}$



FCC

- (FCC-ee)
- (FCC-he)

FCC-hh

- pp 80-100 km circumference
- 100 TeV
- 16 T dipoles (Nb<sub>3</sub>Sn) 20 T HTS
- $\mathcal{L} \sim 5 \times 10^{34}$



# Evolution of Colliders - the future?

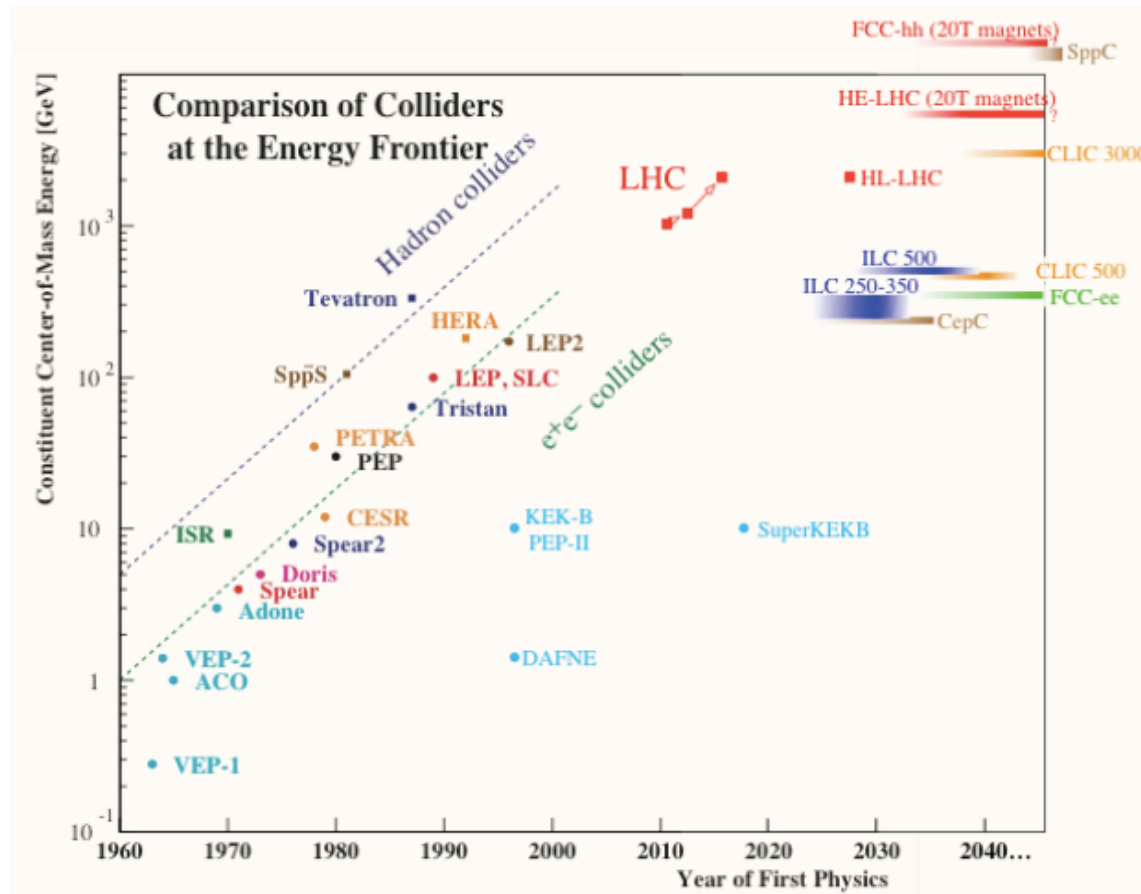

N. Walker

# Evolution of Colliders - the future?

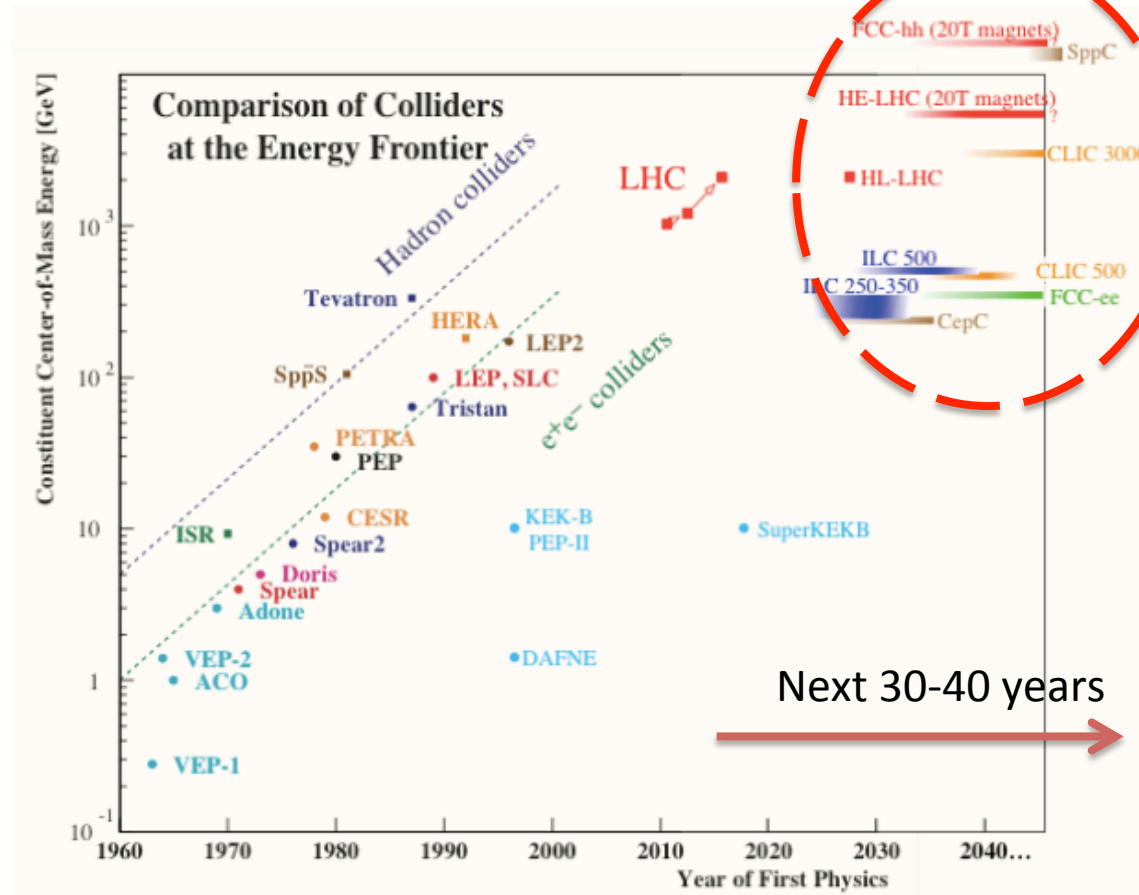

If somebody ask I could give my bet on the time scale

N. Walker

# From R&D to physics

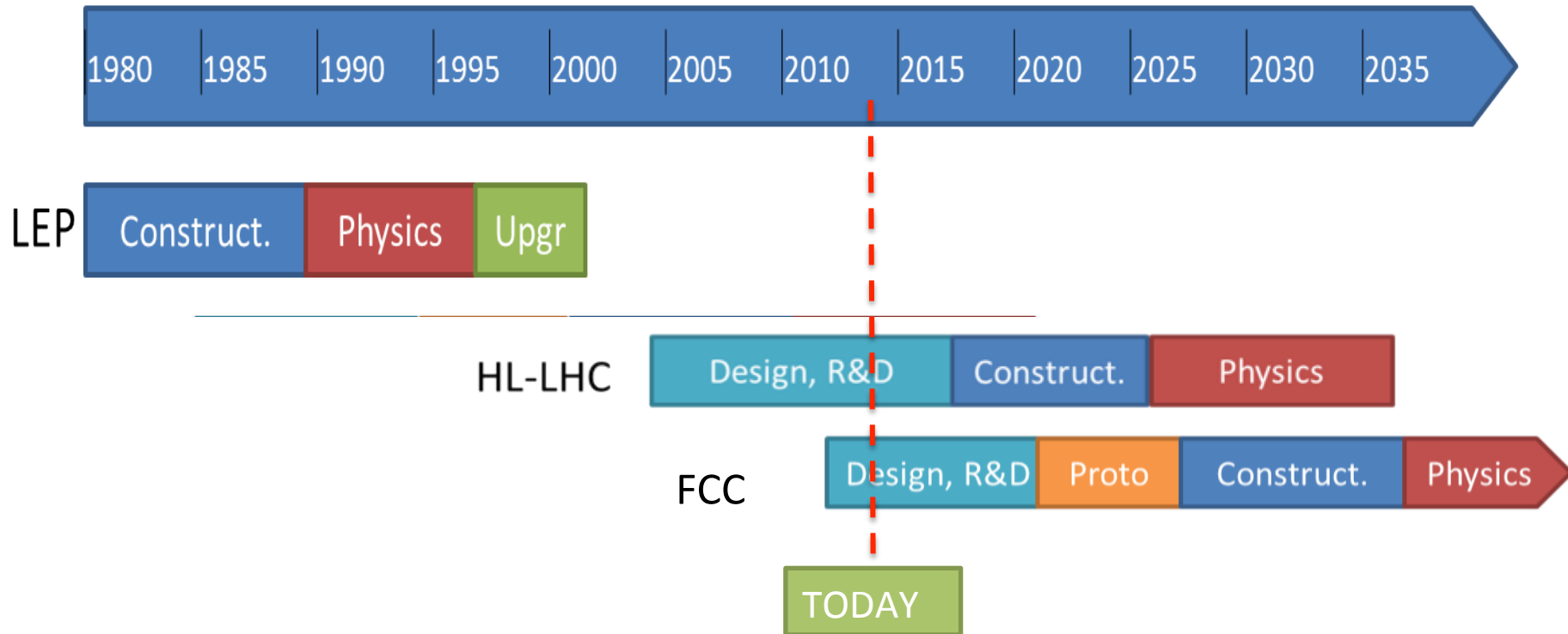



# Conclusions

- The discovery of a Higgs boson brought new light on the next large Machines (HL-LHC, ILC) .
- **HL-LHC will be an impressive Higgs (top) factory, with great potential for discovery.**
- Electron-positron collider would complement the LHC results with **precision measurements**
  - **Linear colliders** are the most advanced path into  $\sim 200\text{-}500$  GeV scale
  - Very large storage rings are attractive up to  $\sim 350$  GeV: CepC, FCC-ee
  - Technologically possible
- **Future very large hadron** colliders for  $\sim 100$  TeV energies under discussion
  - SppC, FCC-pp
  - no strong physics case yet
  - intensive R&D on superconductive magnets needed
- **The coming run at 13 TeV may discover something new, then we will have to re-asses the situation by then.**



N. Walker