

Multiple Consensus Structures for Inferential Style Covariance Models

Stefan Janssen
Bielefeld University

RF00005: tRNA

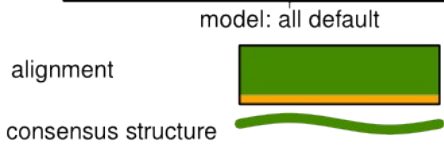
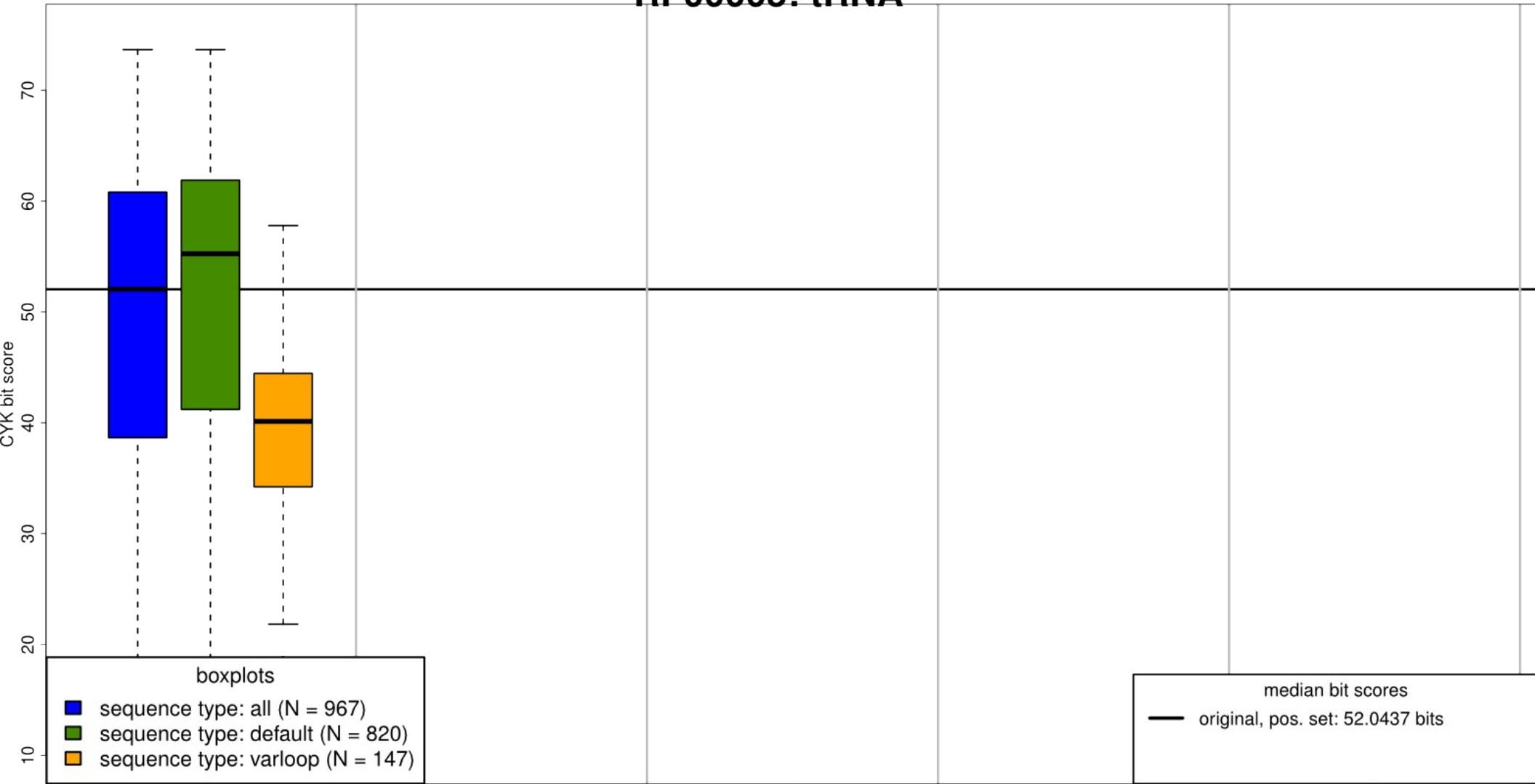

RF00005: tRNA

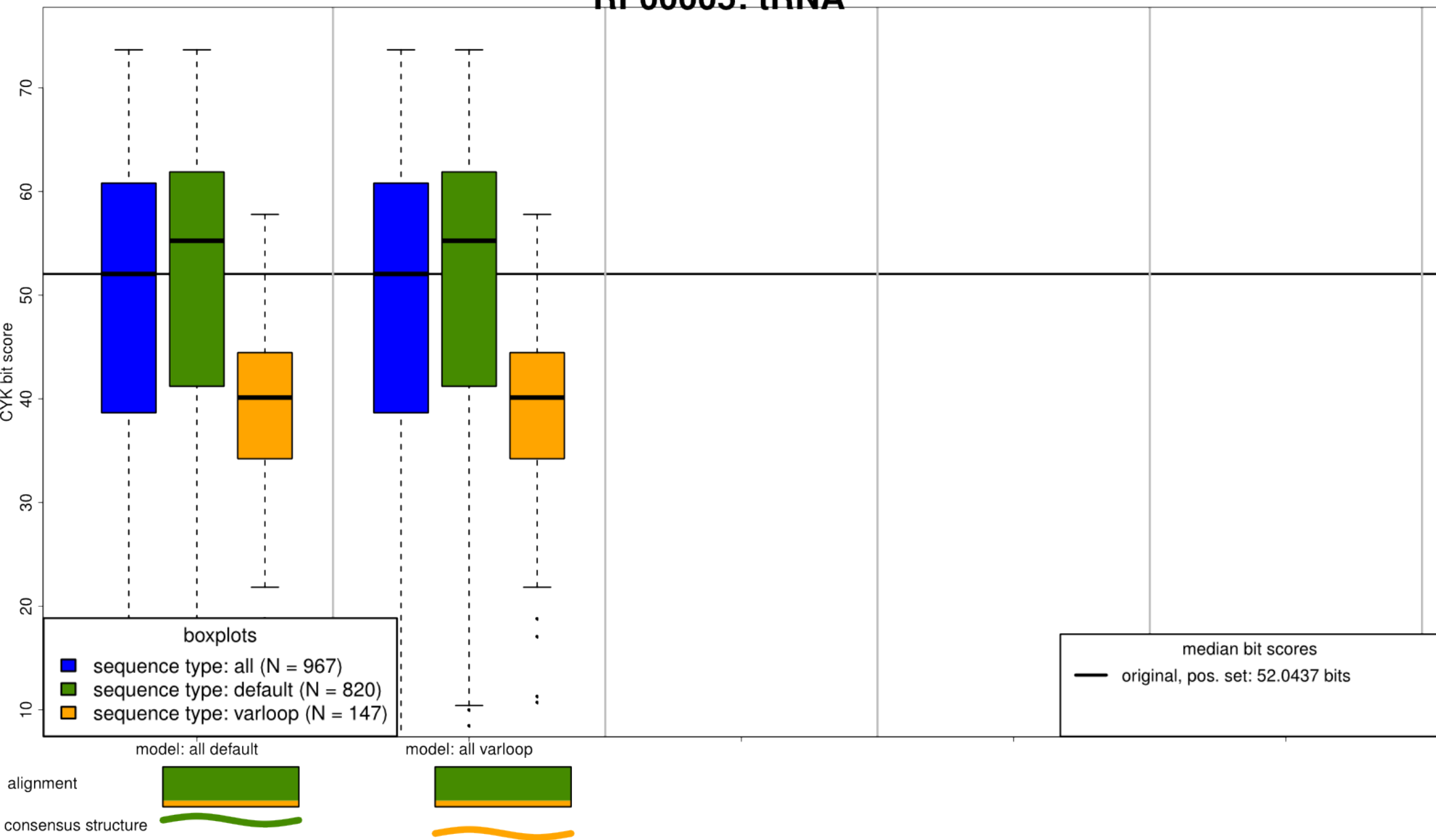

RF00005: tRNA

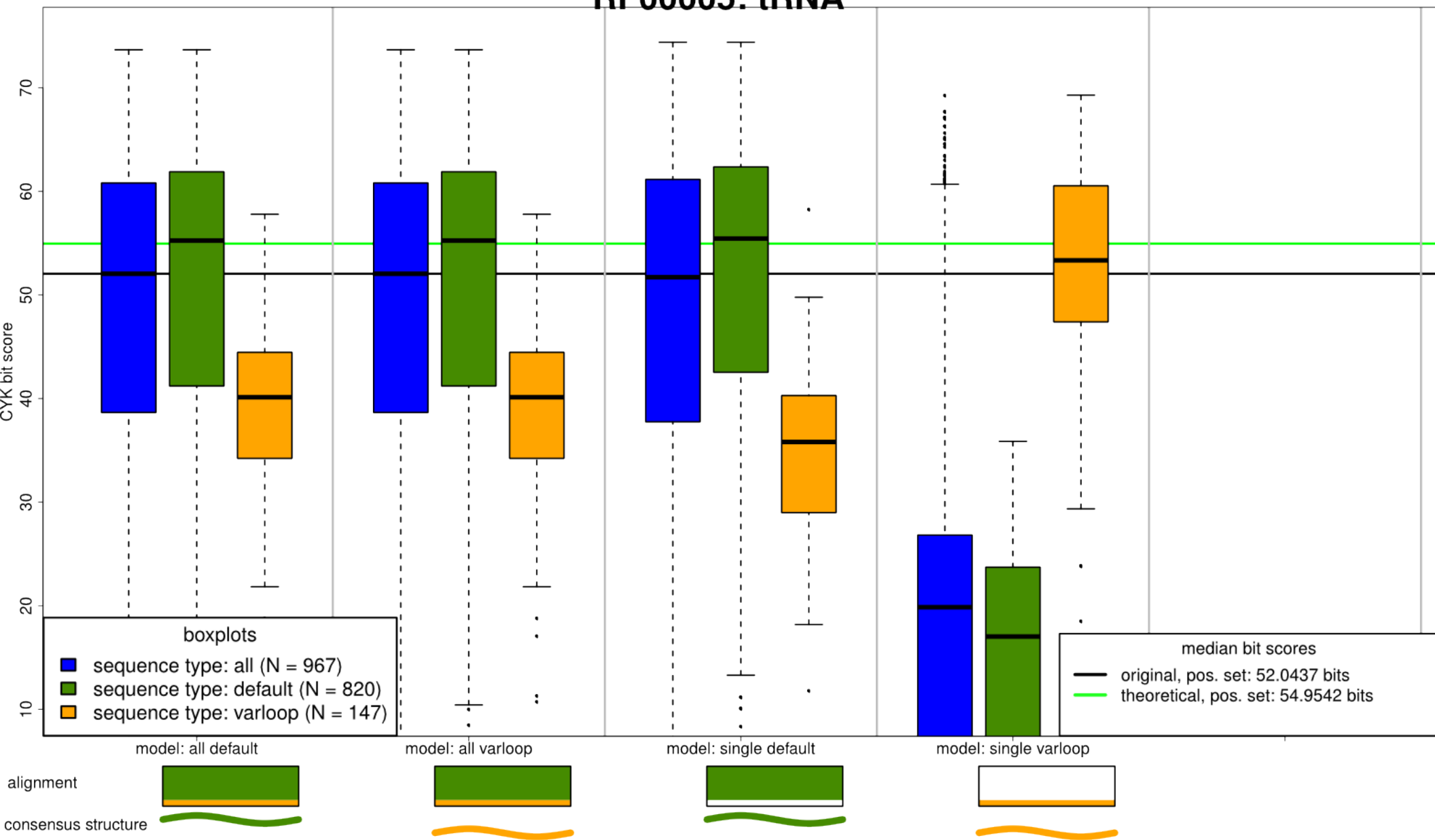

RF00005: tRNA

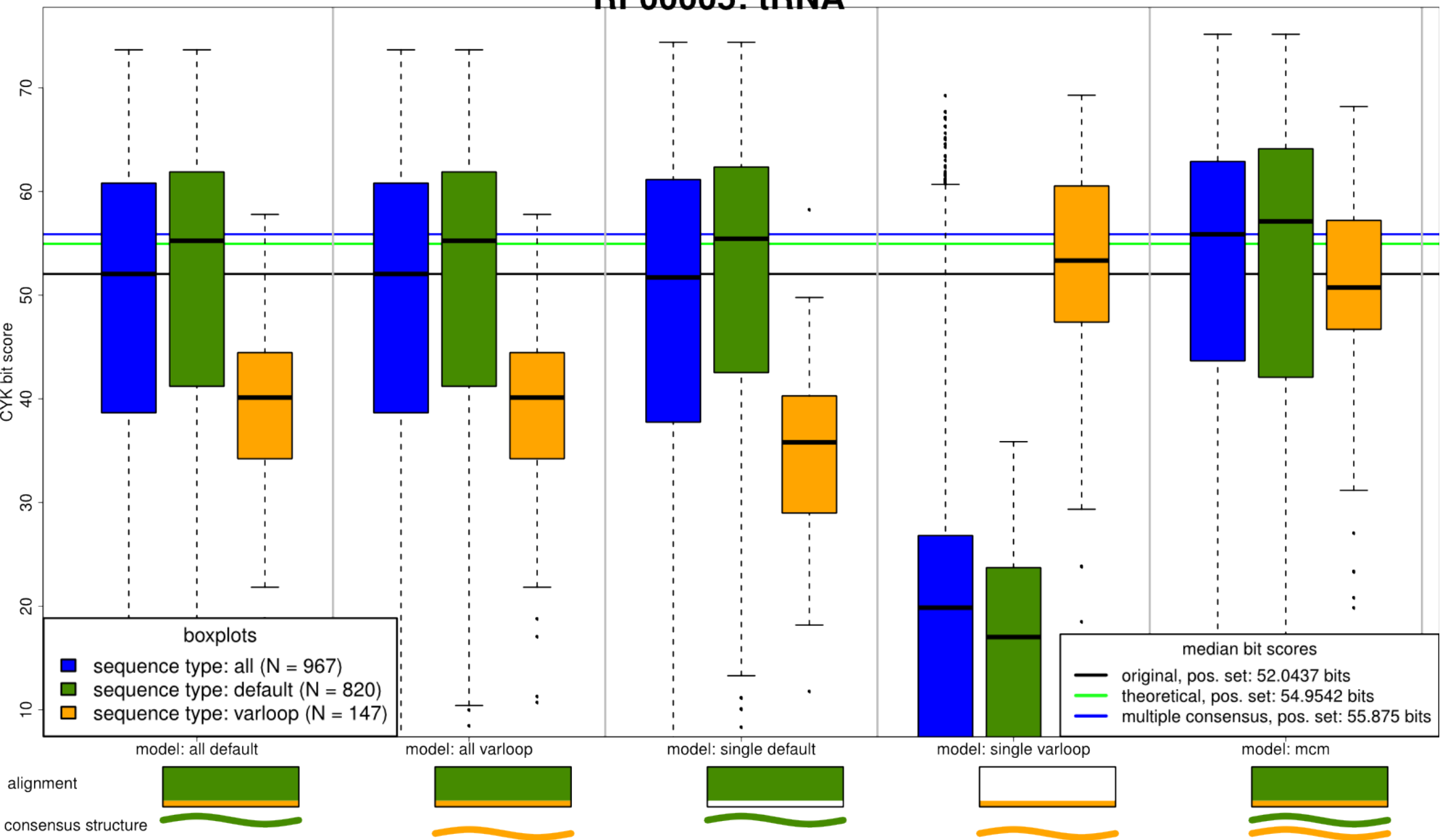

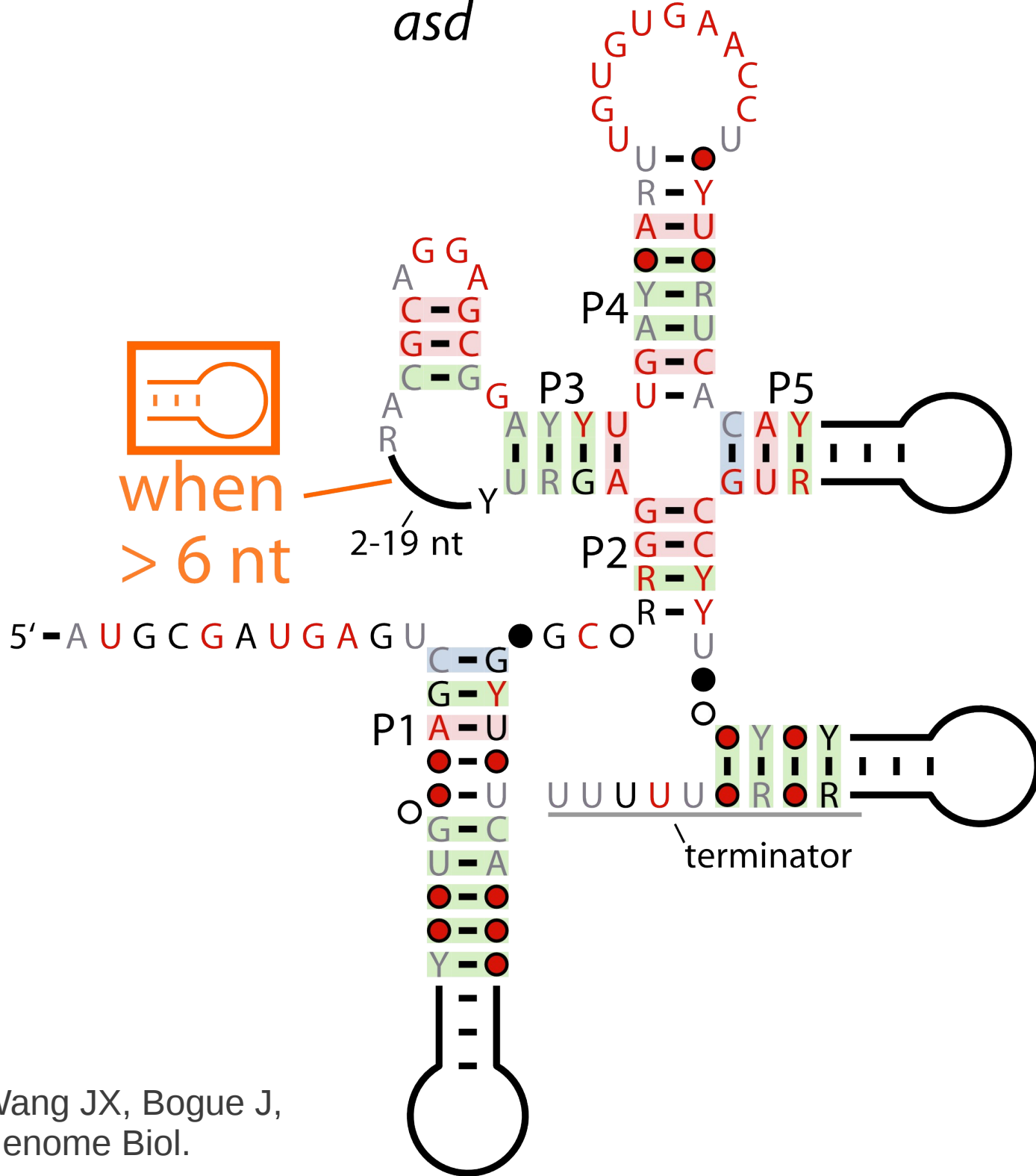

Weinberg Z, Wang JX, Bogue J,
et al. (2010) Genome Biol.

RF01732: asd RNA

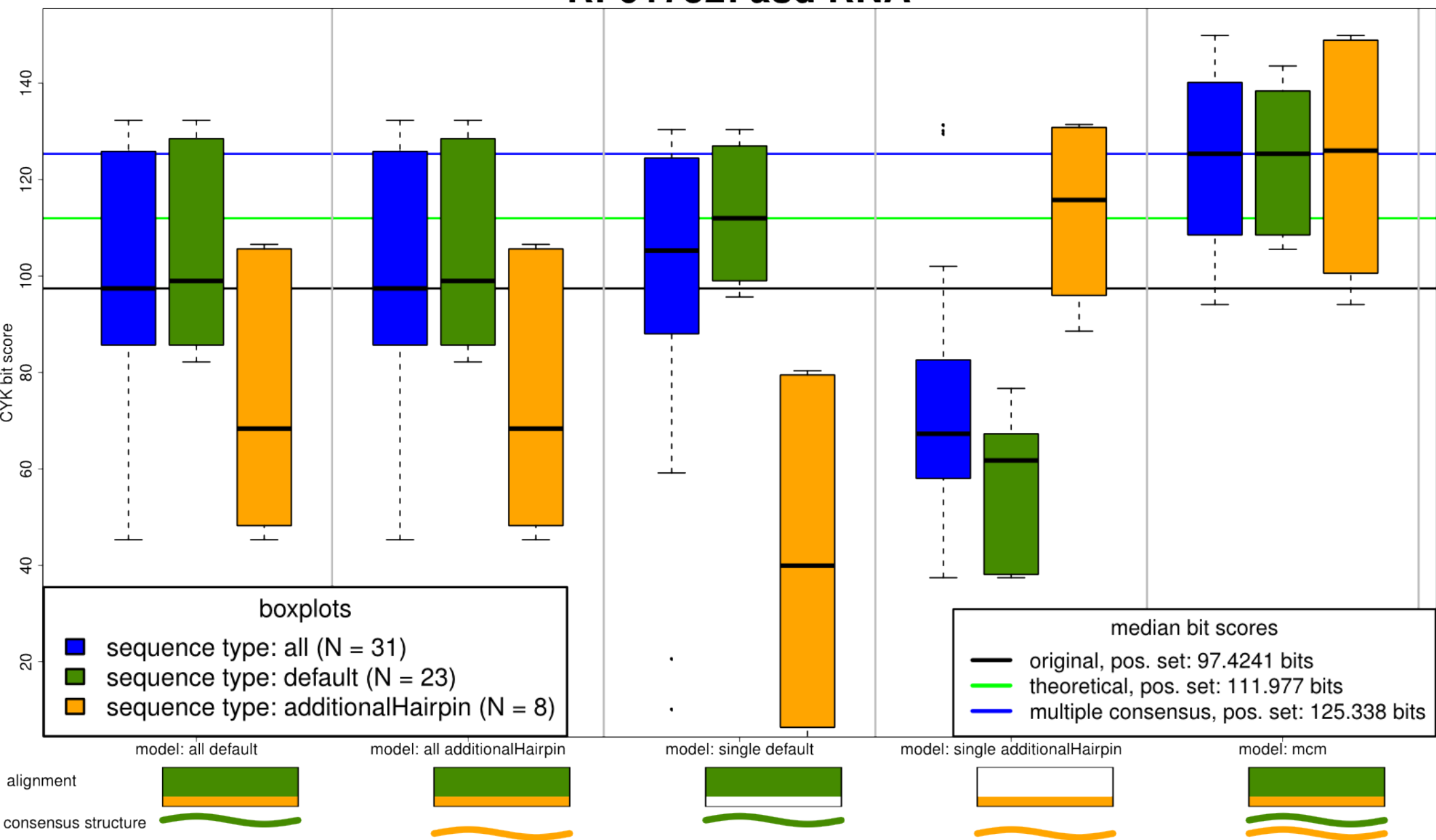

Glm Clan: CL00011

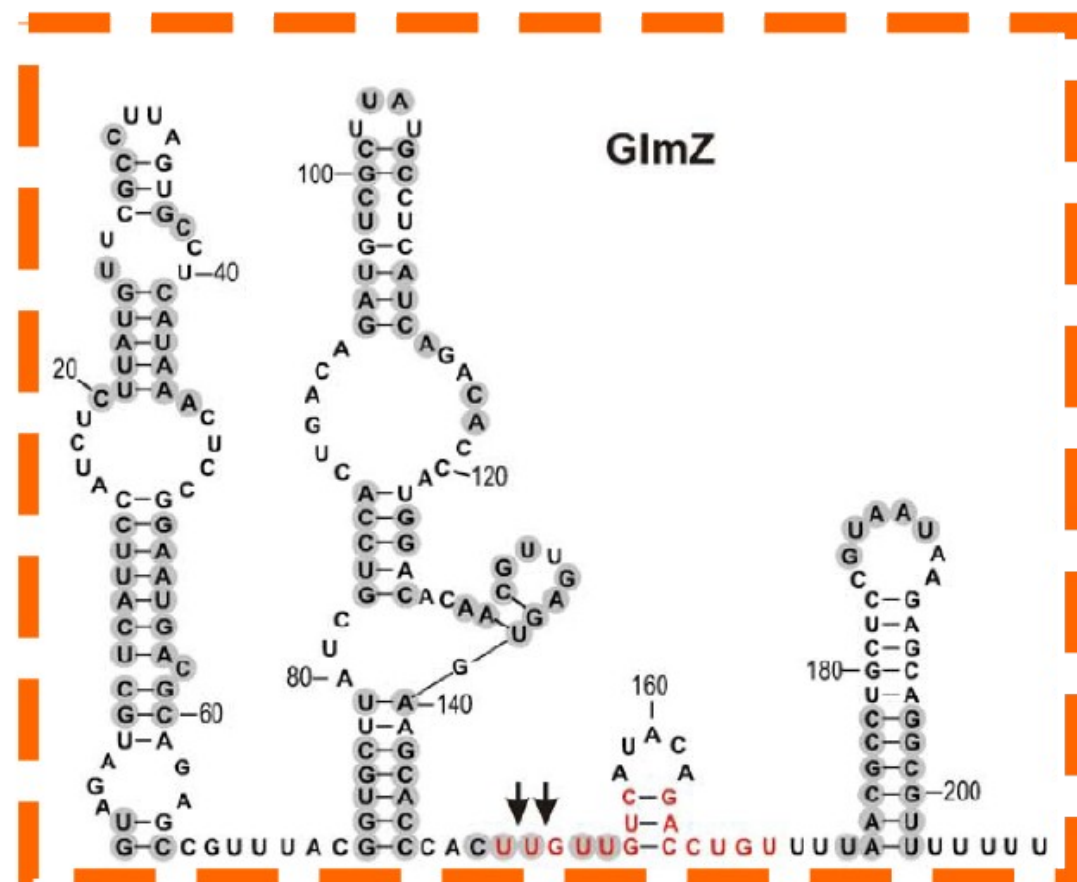
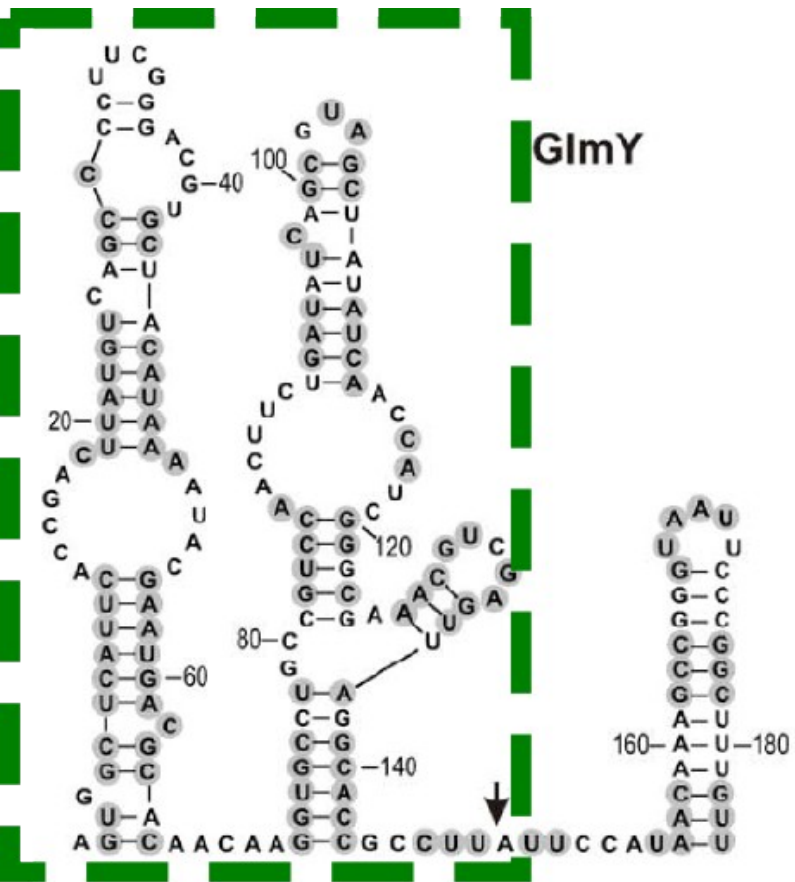

CMCompare link score: 42.9 bit

Urban JH, Vogel J;,
PLoS Biol. 2008

“Discriminatory power of RNA family models”
Höner & Hofacker Bioinformatics 2010

CL00011: The Glm clan contains the RNA families GlmZ_SraJ and GlmY_tke1

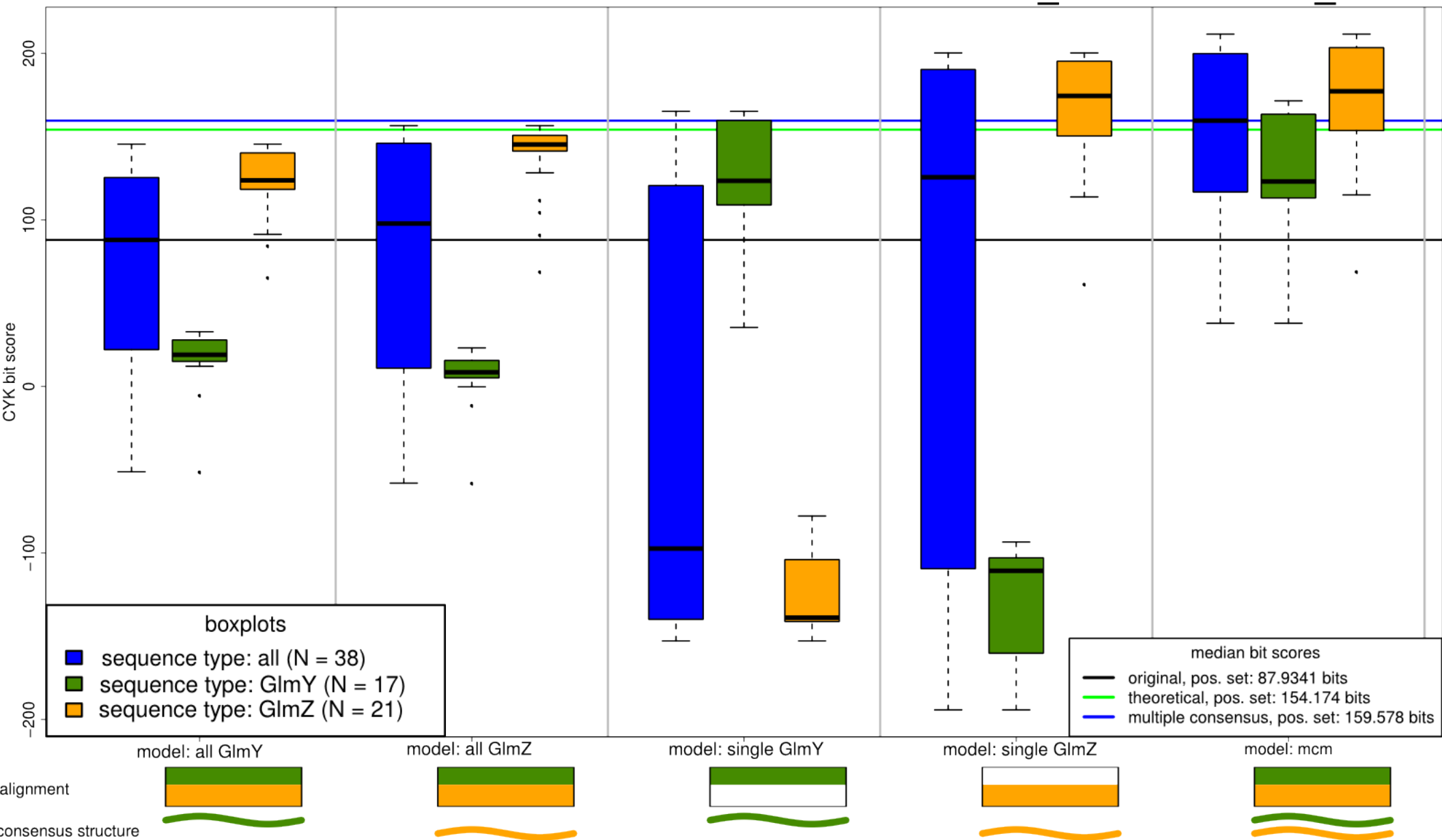

U5 spliceosomal RNA (M Marz, T Kirsten, PF Stadler, J.Mol.Evol. 2008)

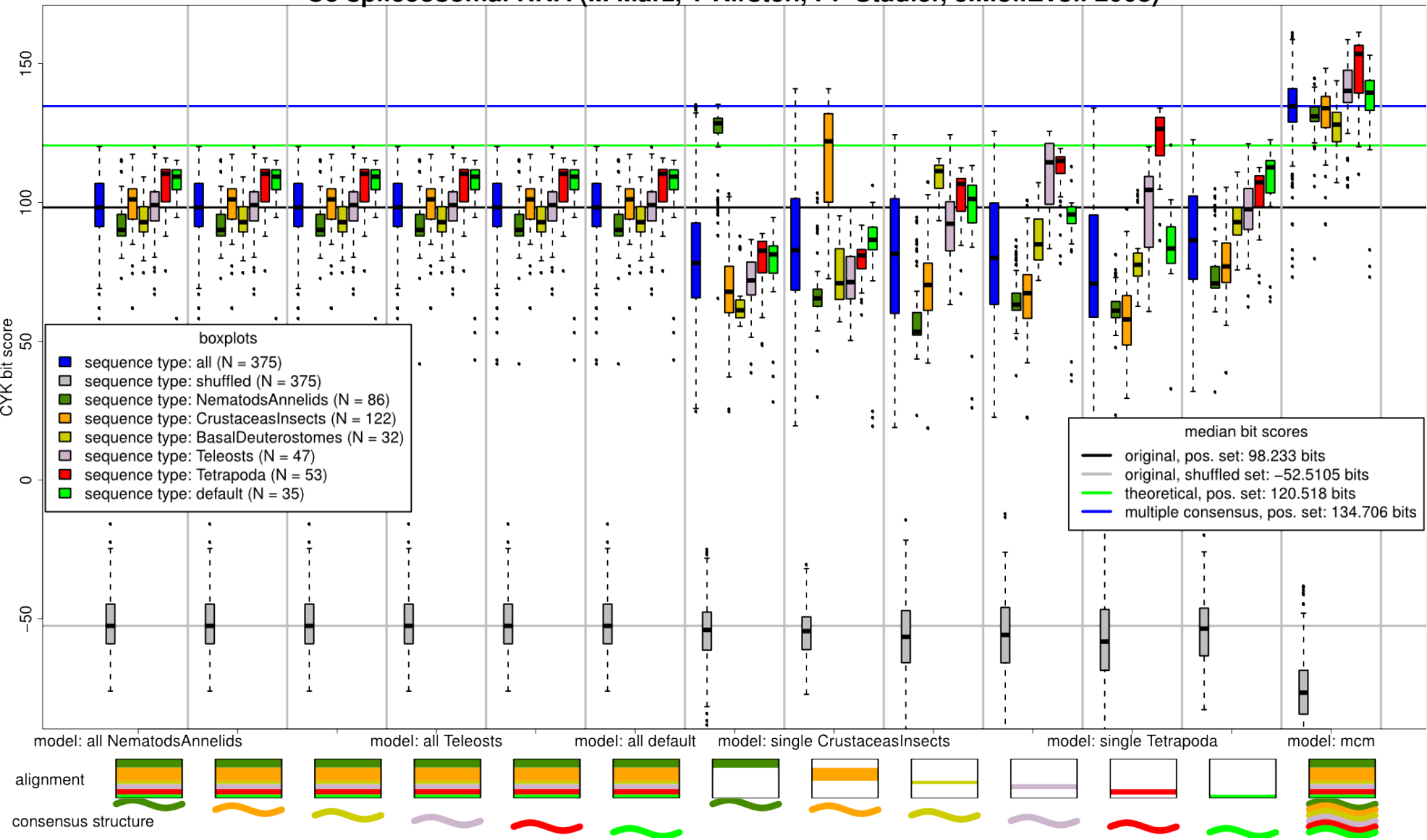

Thank you for your attention

